

CHECKSHEET FOR TECHNICAL DRAWING WORKSHOP ASSIGNMENT (HW2)

(Submit this sheet as your assignment coverpage)

NAME: _____

SECTION #: _____

/10

Design Layout Final Products

- ___ A completed title block on first page of assignment (Description, Filename, Revision) (sheet 1 of 7)
- ___ Use of good drawing practices (straight edge/compass, line weights, scaling, etc.)
- ___ Views drawn correctly (line lengths, size and locations of features)
- ___ Appropriate placement/alignment between views
- ___ Use of centerlines and center marks (where appropriate) in all standard (Front/Top/Right) views
- ___ Use of construction lines (where appropriate) to align views/features (sheets 5-7)
- ___ Inclusion of missing dimensions on last page of assignment (sheet 7 of 7)
- ___ 3 identified, described, and illustrated hand-sketching principles/techniques that you may have struggled with but which added significant value to your finished product in this assignment

Above and Beyond (Exemplary)

- ___ Exceptional overall neatness (standard and iso views)
- ___ Clean dimensioning scheme on sheet 7 of 7
- ___ Other: _____

NOTE: the mentors will use assignment checksheets to grade your work. Be sure to include the checksheet as your assignment cover page at submission. For this assignment, use Adobe Scan (or similar) to convert your work to a pdf. Save your submission as “HW2_Firstname Lastname” and upload your completed assignment to your submission folder in OneDrive. Ask questions if you need clarification on any of the tasks.

Point Deductions

___ No cover page (-0.5)

___ Not a pdf (-0.5)

___ Poor quality scans (-0.5)

___ Incorrect filename (-0.5)

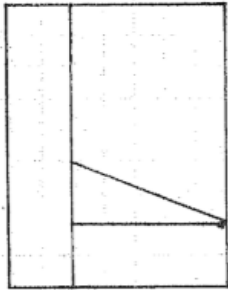

TOP

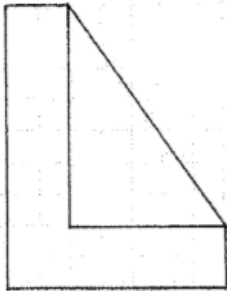

FRONT

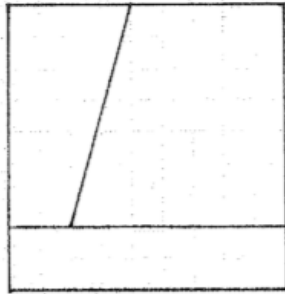

RIGHT

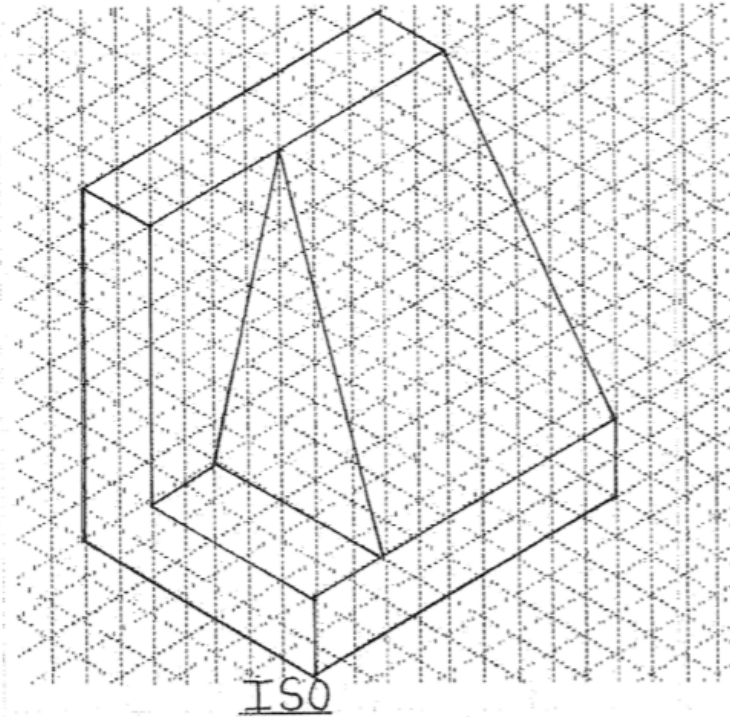

ISO

PROPRIETARY AND CONFIDENTIAL THE INFORMATION CONTAINED IN THIS DRAWING IS THE SOLE PROPERTY OF UNIVERSITY OF IDAHO, ME DEPARTMENT. ANY REPRODUCTION IN PART OR AS A WHOLE WITHOUT THE WRITTEN PERMISSION OF UNIVERSITY OF IDAHO, ME DEPARTMENT IS PROHIBITED.		DIMENSIONS ARE IN INCHES THIRD ANGLE PROJECTION 		PROJECT TITLE: Project Title
DEFAULT TOLERANCES: LINEAR: X. ± .25 X.X ± .1 X.XX ± .01 X.XXX ± .002		ANGULAR: X. ± 2 X.X ± 1 X.XX ± 0 30'		UNIVERSITY OF IDAHO ME DEPARTMENT
DESCRIPTION: FILE NAME/PART NUMBER:		SHEET: 1 OF 7	REVISION:	
		SCALE: 1:8		

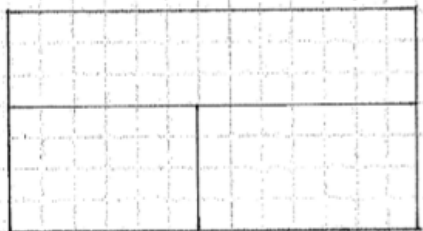

TOP

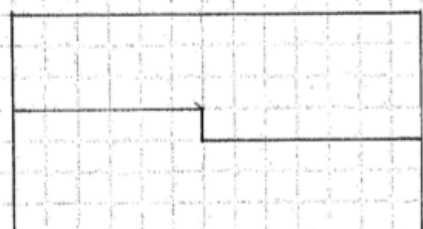

FRONT

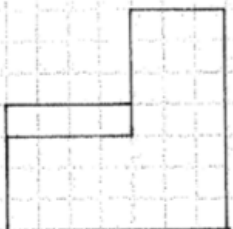

RIGHT

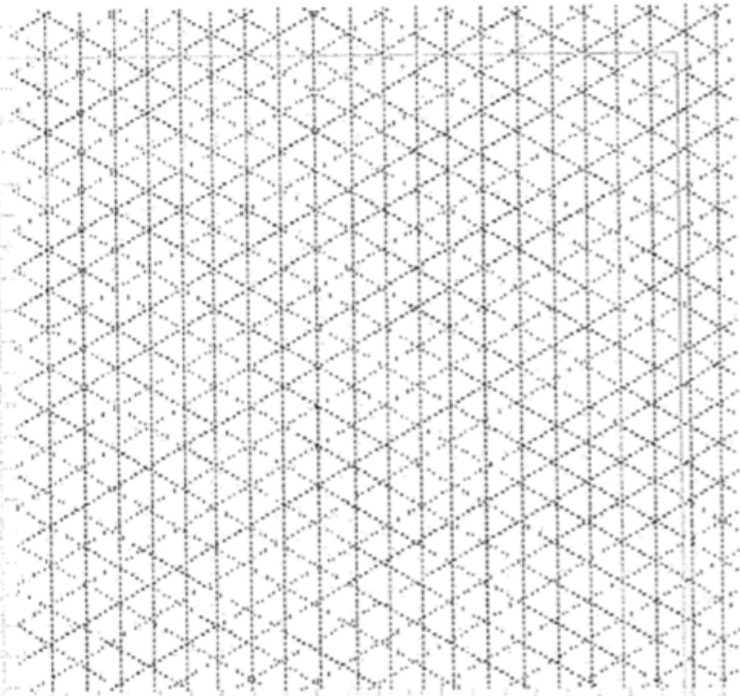

Note: It's okay if your isometric drawing goes a little outside the grid lines.

PROPRIETARY AND CONFIDENTIAL THE INFORMATION CONTAINED IN THIS DRAWING IS THE SOLE PROPERTY OF UNIVERSITY OF IDAHO, ME DEPARTMENT. ANY REPRODUCTION IN PART OR AS A WHOLE WITHOUT THE WRITTEN PERMISSION OF UNIVERSITY OF IDAHO, ME DEPARTMENT IS PROHIBITED.		DIMENSIONS ARE IN INCHES THIRD ANGLE PROJECTION	PROJECT TITLE: Project Title
DESCRIPTION: FILE NAME/PART NUMBER:		UNIVERSITY OF IDAHO ME DEPARTMENT	
DEFAULT TOLERANCES: LINEAR: X.±.25 X.X±.1 X.XX±.01 X.XXX±.002		SHEET: 2 OF 7 SCALE: 1:8	
ANGULAR: X.± 2 X.X± 1 X.XX ± 0 30'		REVISION:	

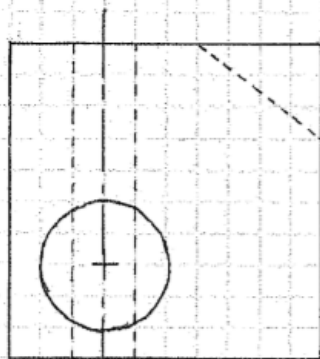

FRONT

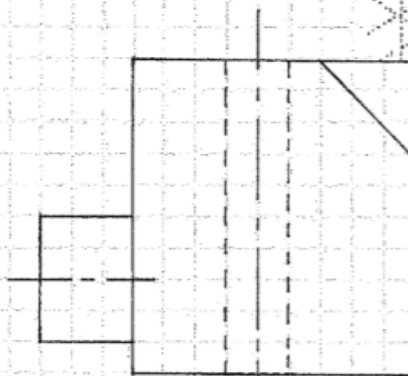

RIGHT

Note: Add both the isometric and top views.

<p>PROPRIETARY AND CONFIDENTIAL THE INFORMATION CONTAINED IN THIS DRAWING IS THE SOLE PROPERTY OF UNIVERSITY OF IDAHO, ME DEPARTMENT. ANY REPRODUCTION IN PART OR AS A WHOLE WITHOUT THE WRITTEN PERMISSION OF UNIVERSITY OF IDAHO, ME DEPARTMENT IS PROHIBITED.</p>		<p>PROJECT TITLE: Project Title</p>
<p>DEFAULT TOLERANCES: LINEAR: X, ±.25 X.X ±.1 X.XX ±.01 X.XXX ±.002</p>		<p>DESCRIPTION: FILE NAME/PART NUMBER:</p>
<p>ANGULAR: X, ± 2 X.X ± 1 X.XX ± 0.30</p>		<p>DIMENSIONS ARE IN INCHES THIRD ANGLE PROJECTION </p>
<p>UNIVERSITY OF IDAHO ME DEPARTMENT</p>		<p>SHEET: 3 OF 7 SCALE: 1:8</p>

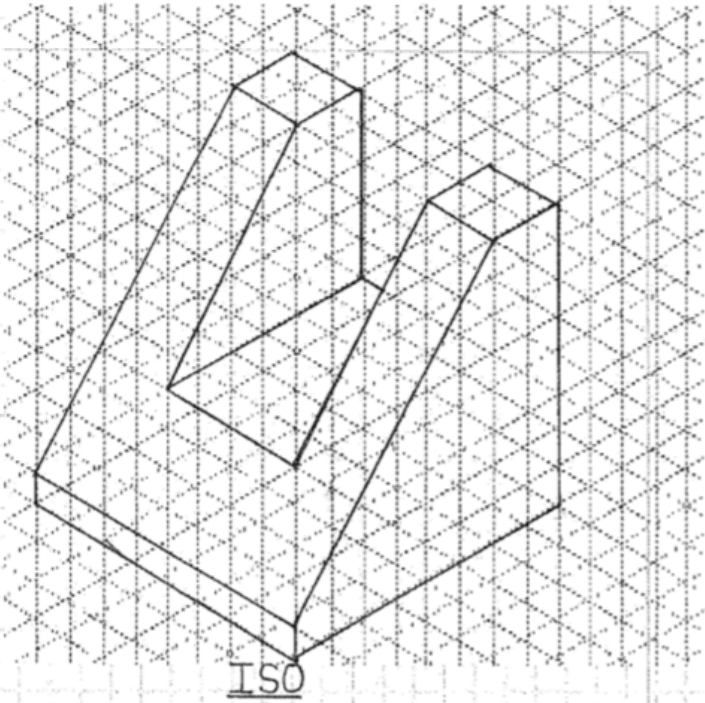

Note: Add all 3 standard views.

PROPRIETARY AND CONFIDENTIAL THE INFORMATION CONTAINED IN THIS DRAWING IS THE SOLE PROPERTY OF UNIVERSITY OF IDAHO ME DEPARTMENT. ANY REPRODUCTION IN PART OR AS A WHOLE WITHOUT THE WRITTEN PERMISSION OF UNIVERSITY OF IDAHO, ME DEPARTMENT IS PROHIBITED.		DIMENSIONS ARE IN INCHES THIRD ANGLE PROJECTION 		PROJECT TITLE: Project Title
DEFAULT TOLERANCES: LINEAR: X. ± .25 X.X ± .1 X.XX ± .01 X.XXX ± .002 ANGULAR: X. ± 2 X.X ± 1 X.XX ± 0.30'		DESCRIPTION: FILE NAME/PART NUMBER:		UNIVERSITY OF IDAHO ME DEPARTMENT
		SHEET: 4 OF 7		REVISION:
		SCALE: 1:8		

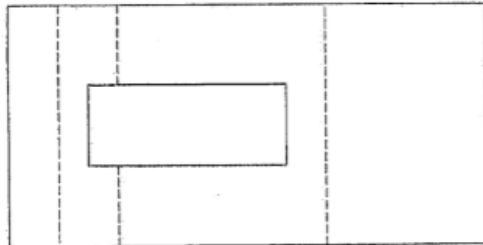
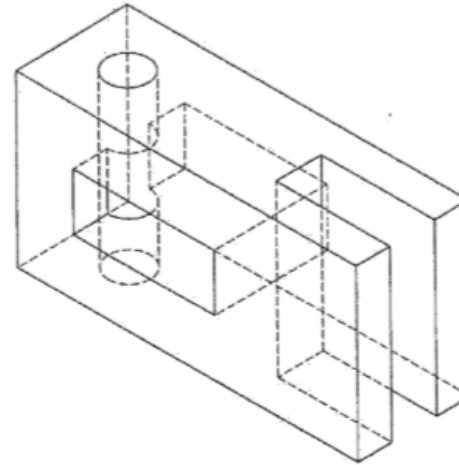
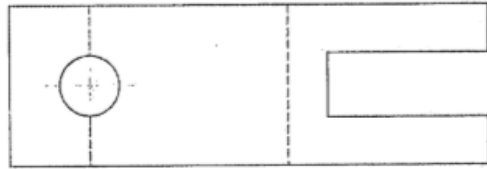

Note: Normally we will not show hidden lines in the isometric view. They are added here just to help you visualize the missing view.

RIGHT

PROPRIETARY AND CONFIDENTIAL THE INFORMATION CONTAINED IN THIS DRAWING IS THE SOLE PROPERTY OF UNIVERSITY OF IDAHO, ME DEPARTMENT. ANY REPRODUCTION IN PART OR AS A WHOLE WITHOUT THE WRITTEN PERMISSION OF UNIVERSITY OF IDAHO, ME DEPARTMENT IS PROHIBITED.		DIMENSIONS ARE IN INCHES THIRD ANGLE PROJECTION		PROJECT TITLE: Project Title	
DEFAULT TOLERANCES: LINEAR: X ± .25 X.X ± .1 X.XX ± .01 X.XXX ± .002		ANGLAR: X ± 2 X.X ± 1 X.XX ± 0 30'		UNIVERSITY OF IDAHO ME DEPARTMENT	
DESCRIPTION: FILE NAME/PART NUMBER:		SHEET: 5 OF 7		REVISION:	
		SCALE: 1:8			

TOP

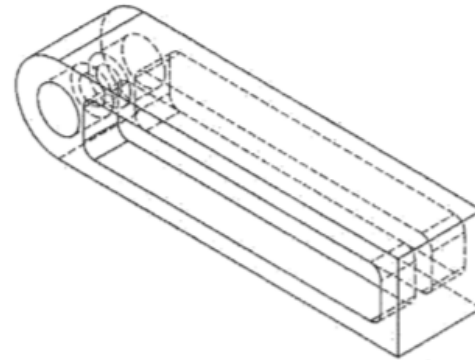

SCALE 1.5:1

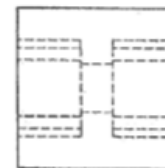
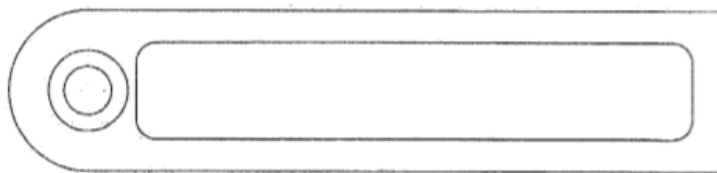

Note: Normally we will not show hidden lines in the isometric view. They are added here just to help you visualize the missing view. Also, we don't normally show tangent edges, but since they are shown, be sure to include them in your top view.

PROPRIETARY AND CONFIDENTIAL THE INFORMATION CONTAINED IN THIS DRAWING IS THE SOLE PROPERTY OF UNIVERSITY OF IDAHO, ME DEPARTMENT. ANY REPRODUCTION IN PART OR AS A WHOLE WITHOUT THE WRITTEN PERMISSION OF UNIVERSITY OF IDAHO, ME DEPARTMENT IS PROHIBITED.		DIMENSIONS ARE IN INCHES THIRD ANGLE PROJECTION 	PROJECT TITLE: Project Title
DEFAULT TOLERANCES:	DESCRIPTION:	UNIVERSITY OF IDAHO ME DEPARTMENT	
LINEAR: X, ±.25 X.X ±.1 X.XX ±.01 X.XXX ±.002	ANGULAR: X, ± 2 X.X ± 1 X.XX ± 0.30'	FILE NAME/PART NUMBER:	SHEET: 6 OF 7 SCALE: 1:8
			REVISION:

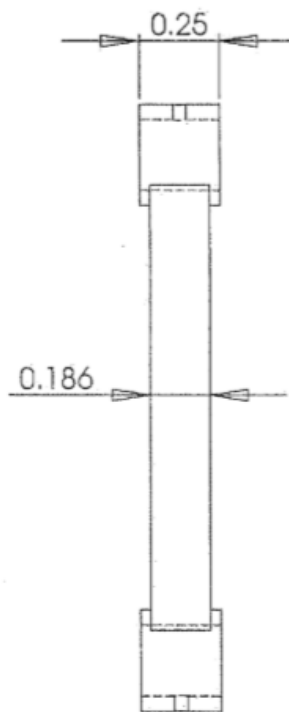
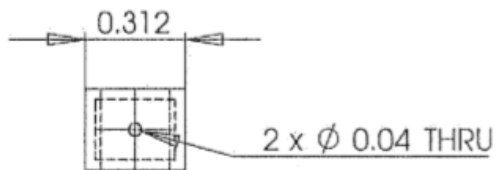

FRONT

SolidWorks Educational License
Instructional Use Only

<p>PROPRIETARY AND CONFIDENTIAL THE INFORMATION CONTAINED IN THIS DRAWING IS THE SOLE PROPERTY OF UNIVERSITY OF IDAHO, ME DEPARTMENT. ANY REPRODUCTION IN PART OR AS A WHOLE WITHOUT THE WRITTEN PERMISSION OF UNIVERSITY OF IDAHO, ME DEPARTMENT IS PROHIBITED.</p>		<p>DIMENSIONS ARE IN INCHES THIRD ANGLE PROJECTION </p>	<p>PROJECT TITLE: Project Title</p>		
<p>DEFAULT TOLERANCES:</p> <table border="0"> <tr> <td>LINEAR: X. ± .25 X.X ± .1 X.XX ± .01 X.XXX ± .002</td> <td>ANGULAR: X. ± 2 X.X ± 1 X.XX ± 0.30'</td> </tr> </table>		LINEAR: X. ± .25 X.X ± .1 X.XX ± .01 X.XXX ± .002	ANGULAR: X. ± 2 X.X ± 1 X.XX ± 0.30'	<p>DESCRIPTION: FILE NAME/PART NUMBER:</p>	<p>UNIVERSITY OF IDAHO ME DEPARTMENT</p>
LINEAR: X. ± .25 X.X ± .1 X.XX ± .01 X.XXX ± .002	ANGULAR: X. ± 2 X.X ± 1 X.XX ± 0.30'				
		<p>SHEET: 7 OF 7</p>	<p>REVISION:</p>		
		<p>SCALE: 1:8</p>			