

ITEM NO	PART NUMBER	DESCRIPTION	MATERIAL
1	01-05	Crankcase	Alloy Steel
2	01-03	Main Bearing Webs	6061 Alloy
3	01-04	Crank Shaft	Alloy Steel
4	01-06	ConRod	Cast Alloy Steel
5	02-00	Piston Assembly	Various

REVISIONS				
Rev	Description	DrawnBy	CheckedBy	Date
A	Initial Release			

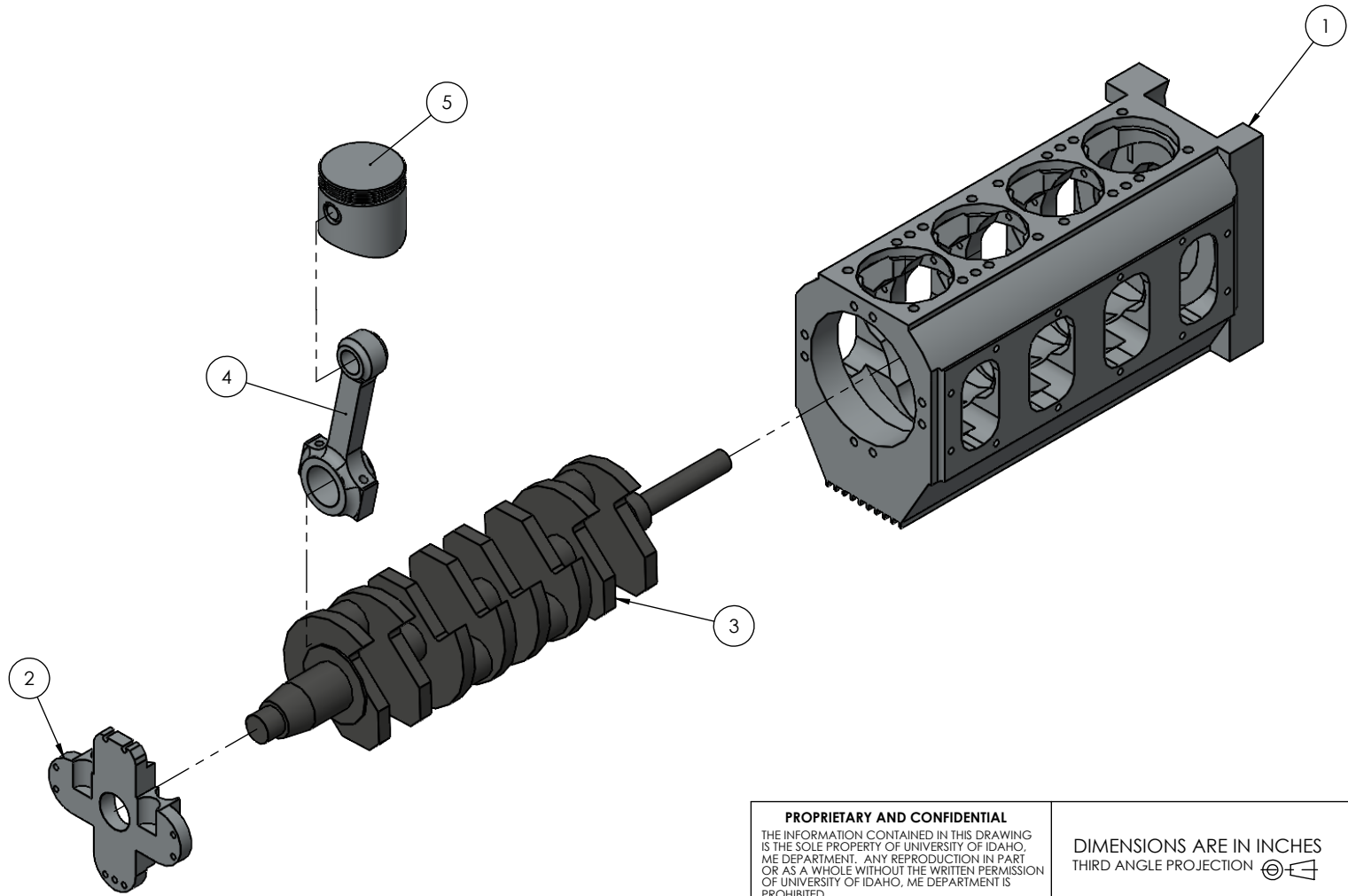

NOTES:
1.

PROPRIETARY AND CONFIDENTIAL THE INFORMATION CONTAINED IN THIS DRAWING IS THE SOLE PROPERTY OF UNIVERSITY OF IDAHO, ME DEPARTMENT. ANY REPRODUCTION IN PART OR AS A WHOLE WITHOUT THE WRITTEN PERMISSION OF UNIVERSITY OF IDAHO, ME DEPARTMENT IS PROHIBITED.		DIMENSIONS ARE IN INCHES THIRD ANGLE PROJECTION		PROJECT TITLE: Project Title	
DEFAULT TOLERANCES: LINEAR: X. ± .25 X.X ± .1 X.XX ± .01 X.XXX ± .002		ANGULAR: X. ± 2 X.X ± 1 X.XX ± 0 30'		UNIVERSITY OF IDAHO ME DEPARTMENT	
DESCRIPTION: Crank Case		FILE NAME/PART NUMBER:		SHEET: 1 OF 1 SCALE: 1:2	
				REVISION:	