

Optimality Criteria Problem Set

1) Use the Fitch algorithm to find the minimum cost of the tree shown below:

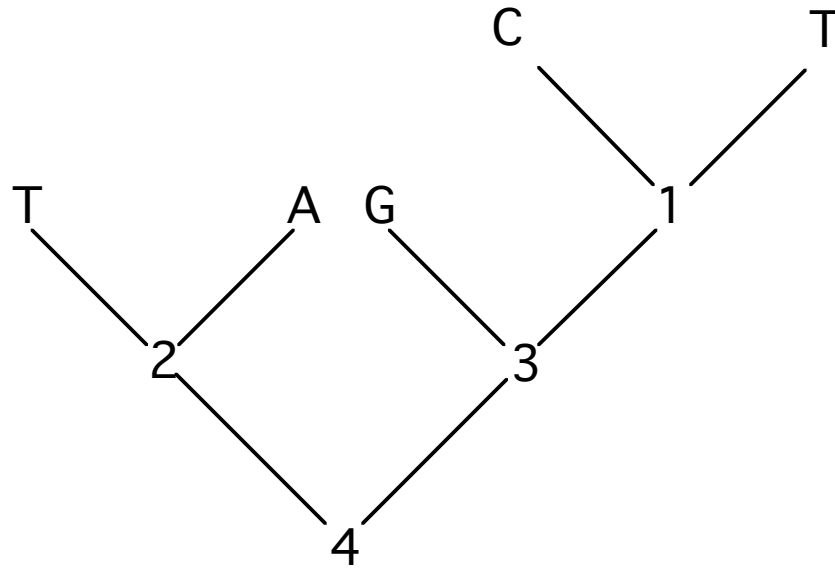

Answer:

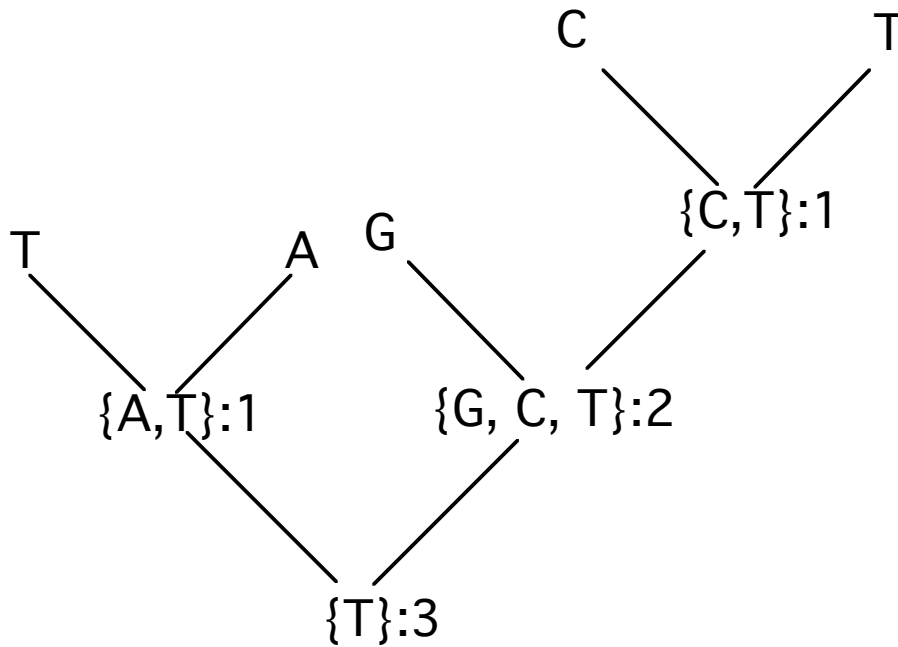

2) Write the likelihood function for the tree and character reconstruction shown below.

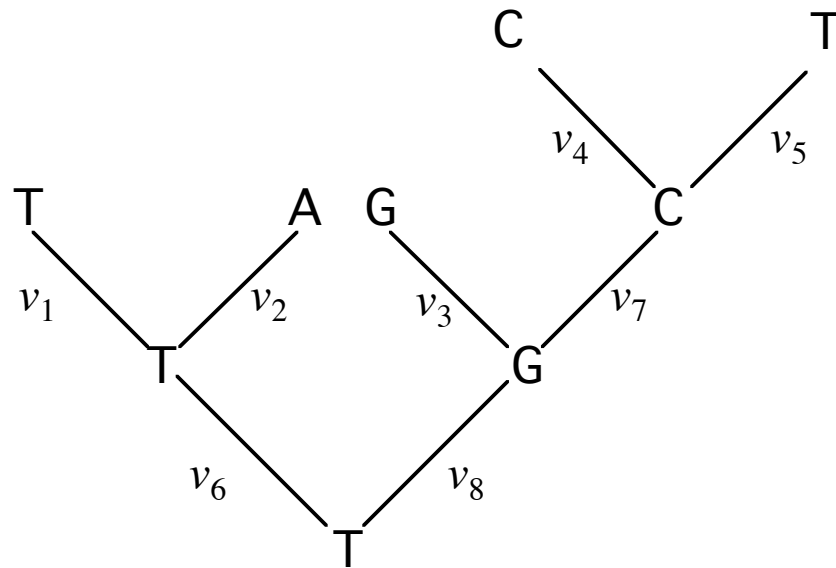

Answer:

$$\Pr(\mathbf{R}|\tau) = \pi_T \times P_{(T,T)}v_6 \times P_{(T,T)}v_1 \times P_{(T,A)}v_2 \times P_{(T,G)}v_8 \times P_{(G,G)}v_3 \times P_{(G,C)}v_7 \times P_{(C,C)}v_4 \times P_{(C,T)}v_5$$

3) Suppose you were interested in optimizing the tree below using a 2:1 weighting of transversions over transitions.

a) Construct the step matrix.

--	2	1	2
2	--	2	1
1	2	--	2
2	1	2	--

b) Show the optimization on the tree.

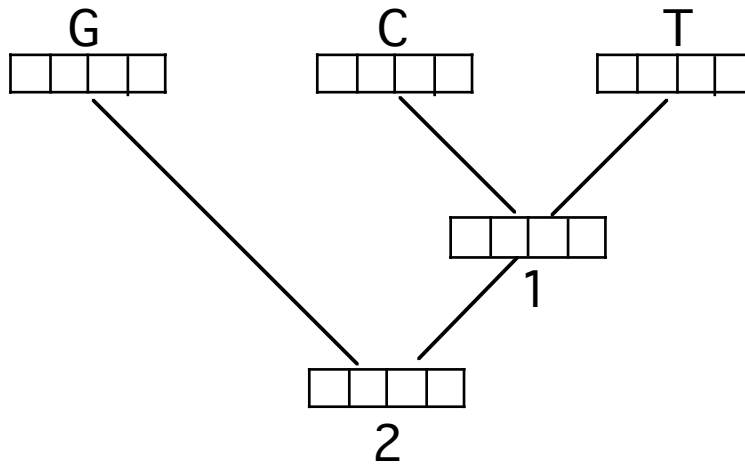

Node 1

$$s_{1(A)} = c_{AC} + c_{AT} = 2 + 2 = 4,$$

$$s_{1(C)} = c_{CC} + c_{CT} = 0 + 1 = 1,$$

$$s_{1(G)} = c_{GC} + c_{GT} = 2 + 2 = 4,$$

$$s_{1(T)} = c_{TC} + c_{TT} = 1 + 0 = 1$$

Node 2

$$\begin{aligned} S_{2(A)} &= \min[s_{1A_j} + c_{A_j}] + c_{AG} \\ &= \min [4, 3, 5, 3] + 1 = 3 + 1 = 4 \end{aligned}$$

$$\begin{aligned} S_{2(C)} &= \min[s_{1C_j} + c_{C_j}] + c_{CG} \\ &= \min [6, 1, 6, 2] + 2 = 1 + 2 = 3 \end{aligned}$$

$$\begin{aligned} S_{2(G)} &= \min[s_{1G_j} + c_{G_j}] + c_{GG} \\ &= \min [5, 3, 4, 3] + 0 = 3 + 0 = 3 \end{aligned}$$

$$\begin{aligned} S_{2(T)} &= \min[s_{1T_j} + c_{T_j}] + c_{TG} \\ &= \min [6, 2, 6, 1] + 2 = 1 + 2 = 3 \end{aligned}$$

