

INSIDE **Out**

Second Edition

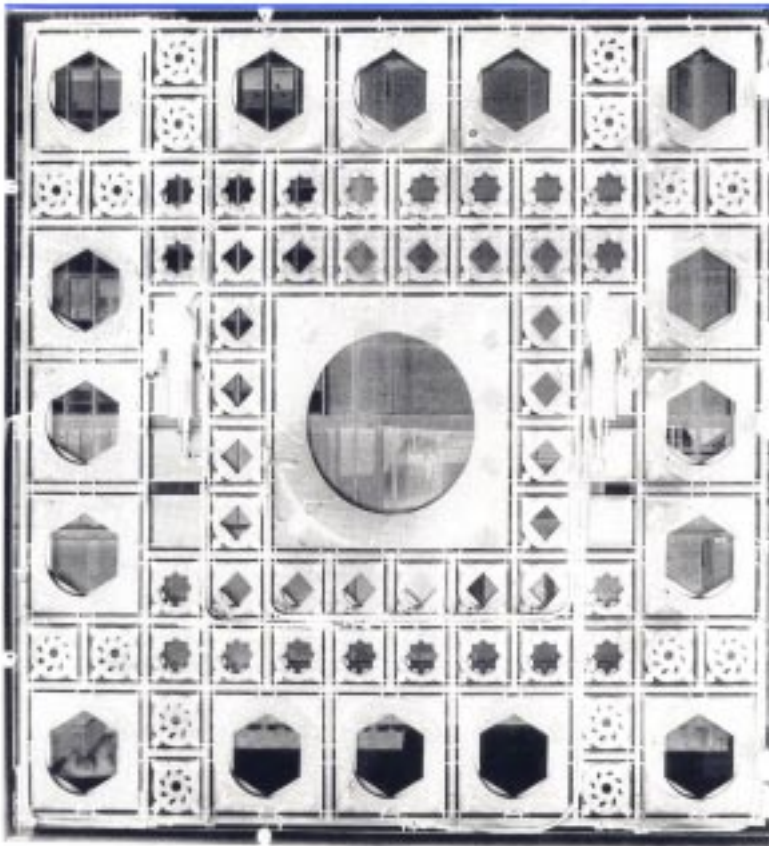

DESIGN
PROCEDURES
FOR PASSIVE
ENVIRONMENTAL
TECHNOLOGIES

App. F GDDM

G. Z. Brown

Bruce Haglund

Joel Loveland

John S. Reynolds

M. Susan Ubbelohde

Illustrations by Amy Dowty

CONTENTS

- 1. A-7 AND A-8**
- 2. A-9 AND A-10**
- 3. A-11 AND A-12**
- 4. A-13**
- 5. A-14**
- 6. A-15**
- 7. A-16**
- 8. A-17**
- 9. A-18**
- 10. A-19 AND A-20**
- 11. A-21 AND A-22**
- 12. A-23 AND A-24**
- 13. A-30**
- 14. A-31**
- 15. A-32**
- 16. A-33**
- 17. A-34**
- 18. A-35**
- 19. A-36**
- 20. A-37**

Reprinted, with permission, from Millet and Bedrick, "Manual: Graphic Daylight Design Method."

APPENDIX F

GDDM FOOTPRINTS

A-7 $H/W = 0.5$; $S/H = 0.0$

APP F 1

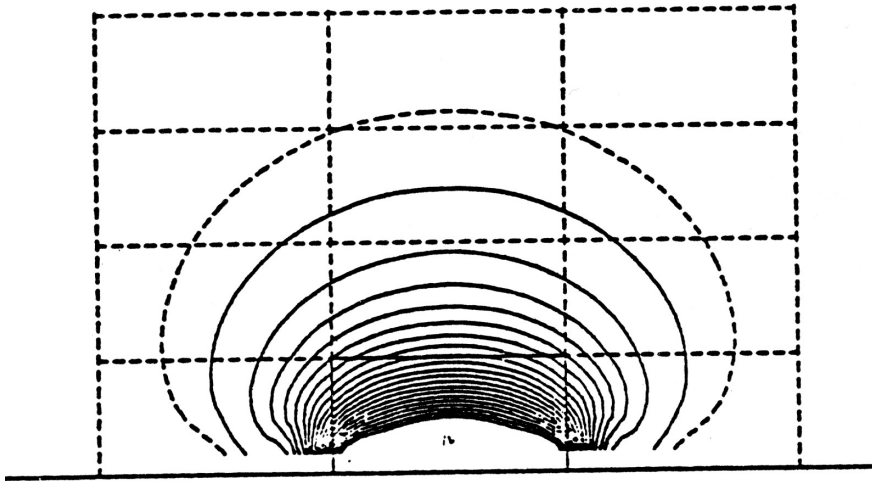

A-8 $H/W = 0.5$; $S/H = 0.5$

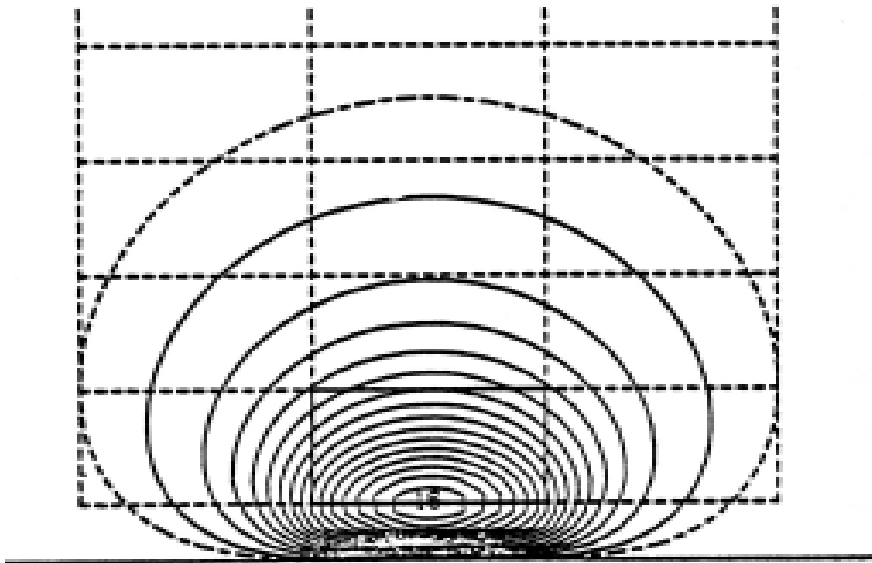

APPENDIX F

GDDM FOOTPRINTS

A-9 $H/W = 0.5$; $S/H = 1.0$

APP F 2

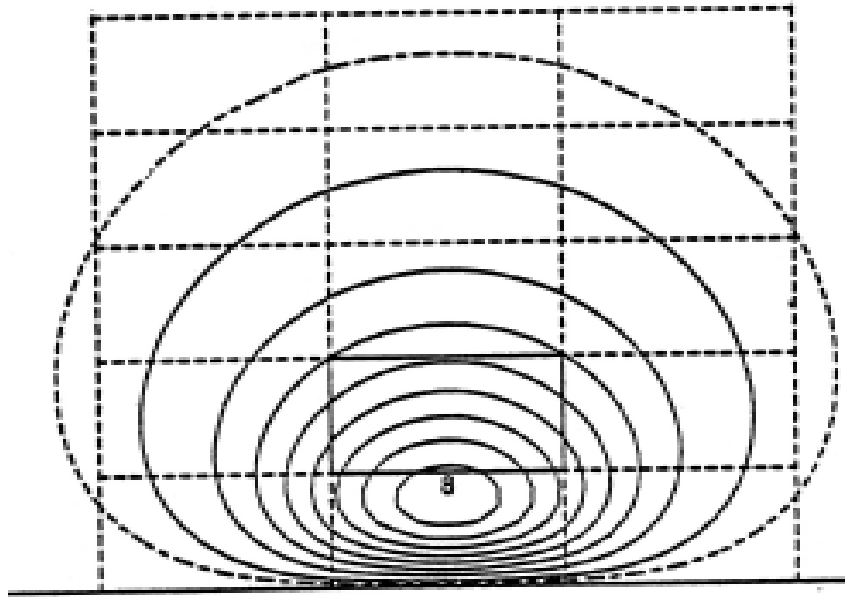

A-10 $H/W = 0.5$; $S/H = 2.0$

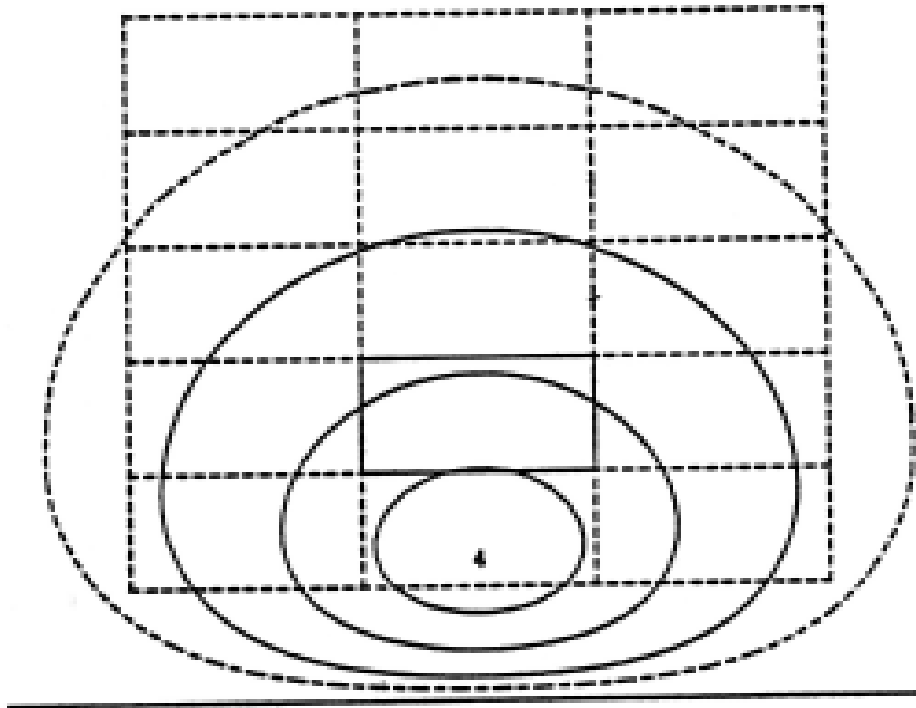

APPENDIX F

GDDM FOOTPRINTS

A-11 $H/W = 0.5$; $S/H = 3.0$

APP F

3

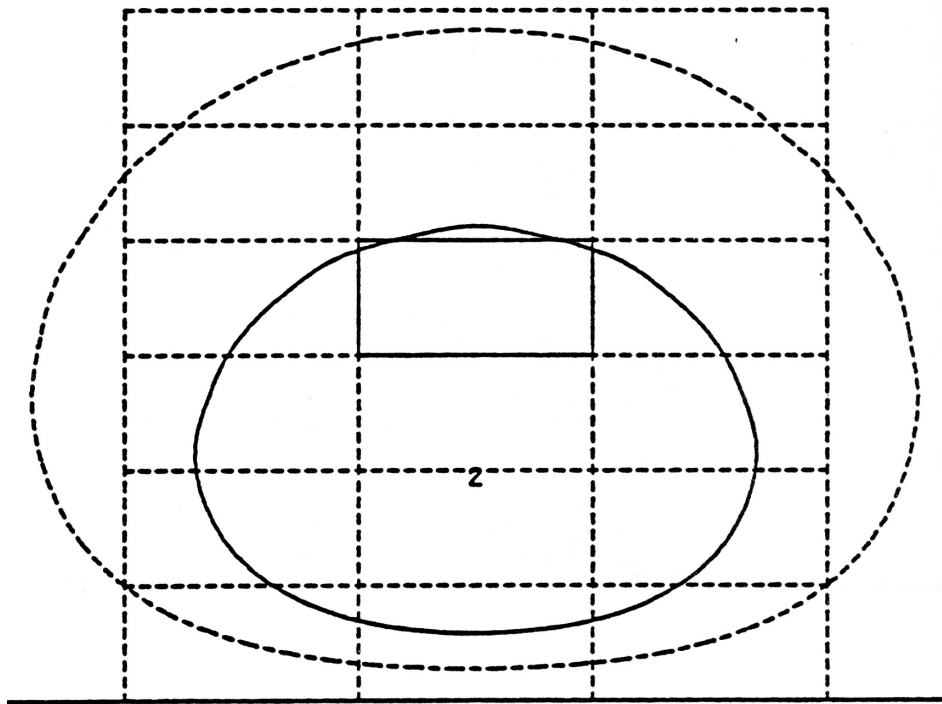

A-12 $H/W = 0.5$; $S/H = 4.0$

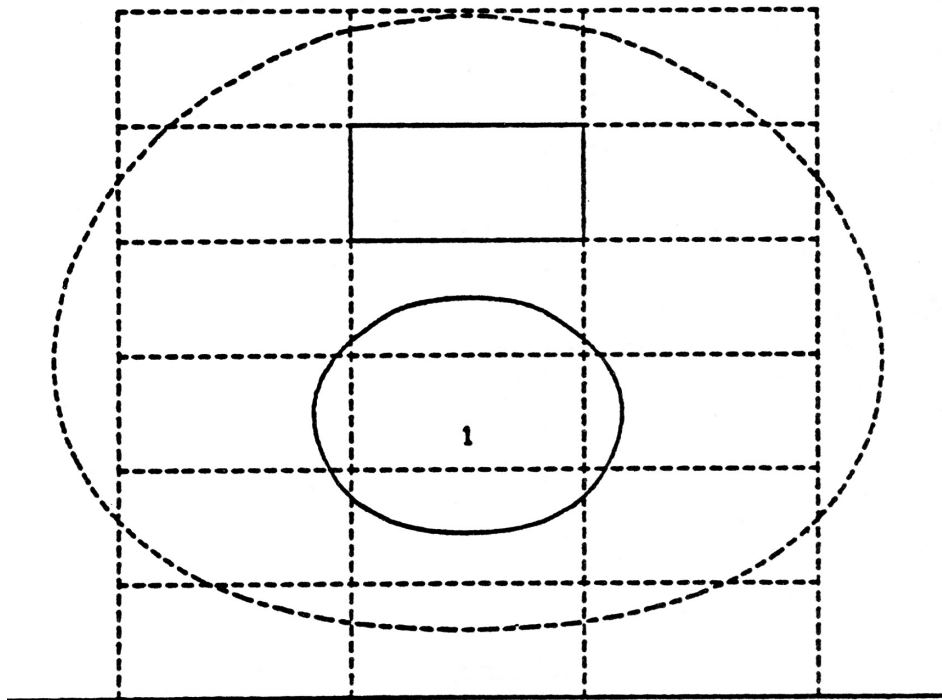

APPENDIX F

GDDM FOOTPRINTS

A-13 H/W = 1.0; S/H = 0.0

APP F 4

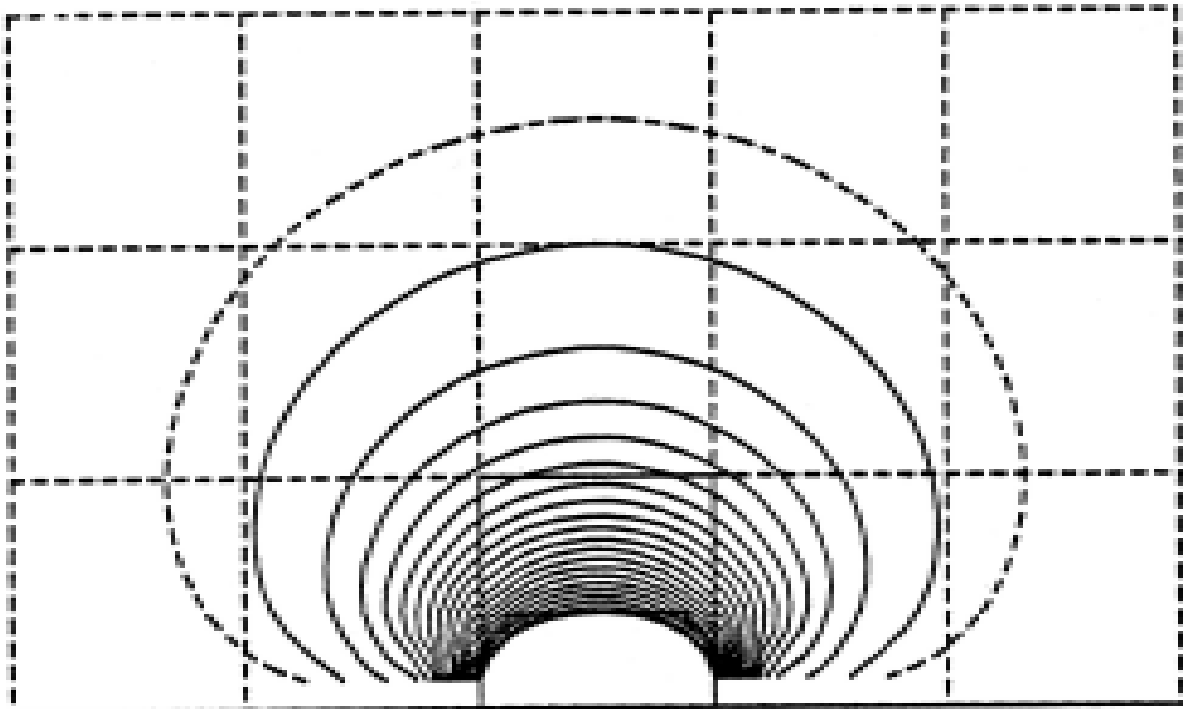

APPENDIX F

GDDM FOOTPRINTS

A-14 H/W = 1.0; S/H = 0.5

APP F 5

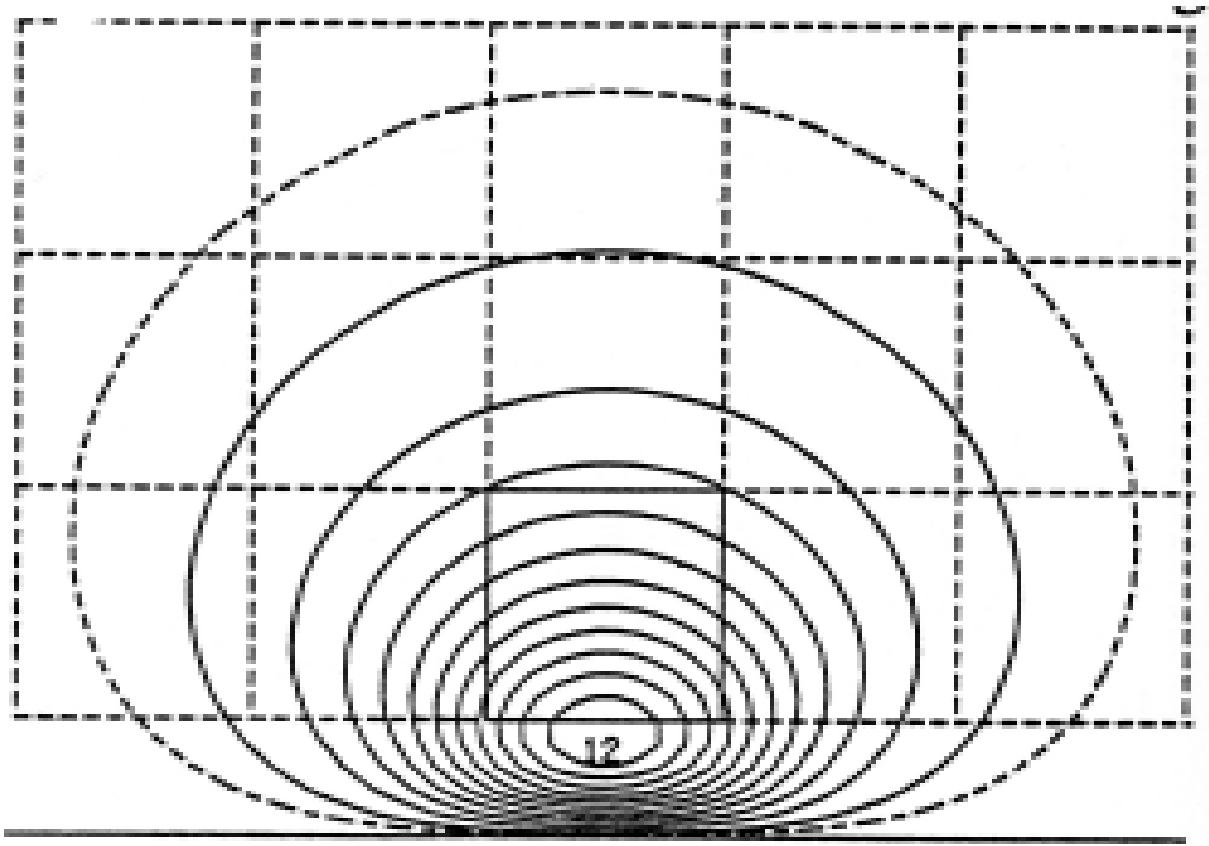

APPENDIX F

GDDM FOOTPRINTS

A-15 H/W = 1.0; S/H = 1.0

APP F 6

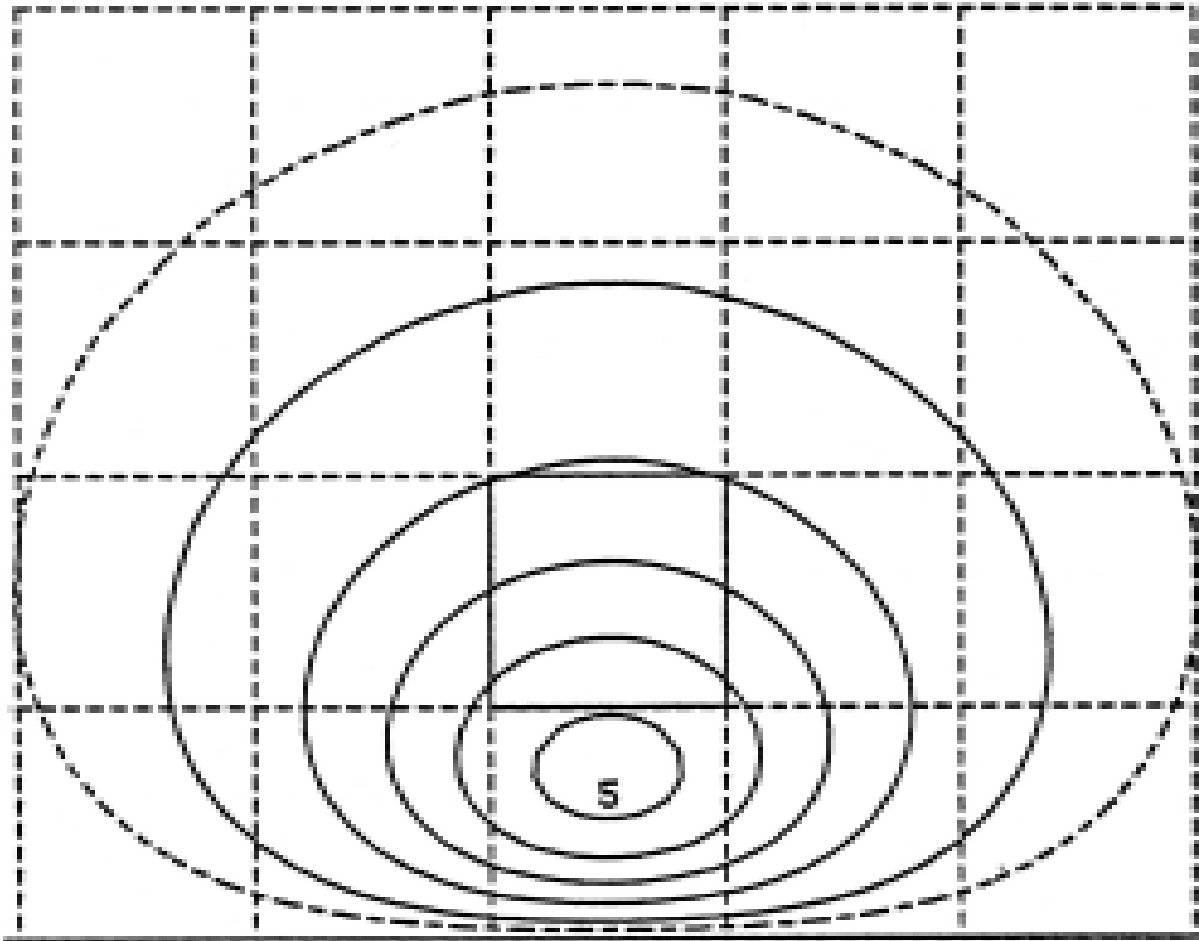

APPENDIX F

GDDM FOOTPRINTS

A-16 H/W = 1.0; S/H = 2.0

APP F 7

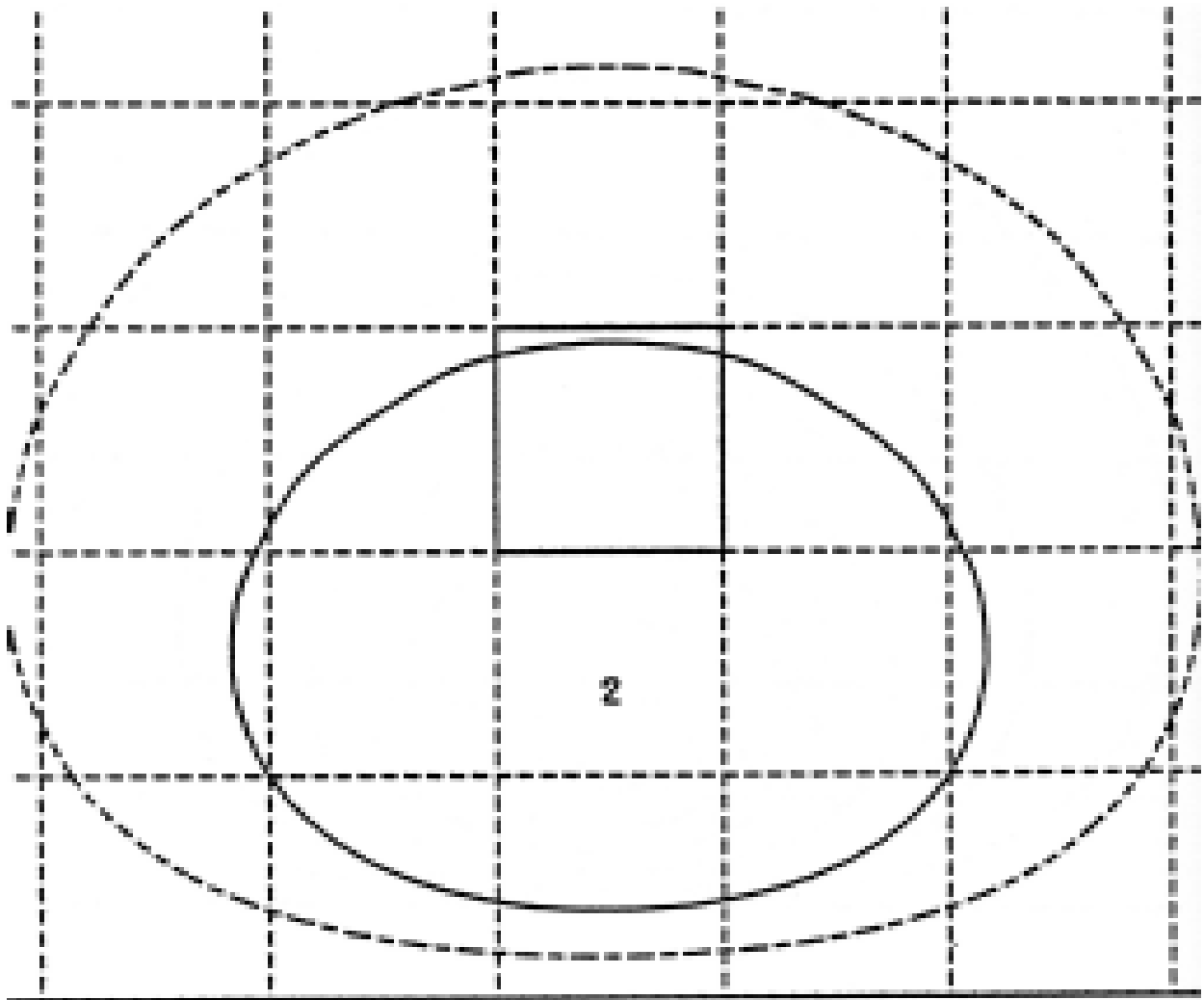

APPENDIX F

GDDM FOOTPRINTS

A-17 H/W = 1.0; S/H = 3.0

APP F 8

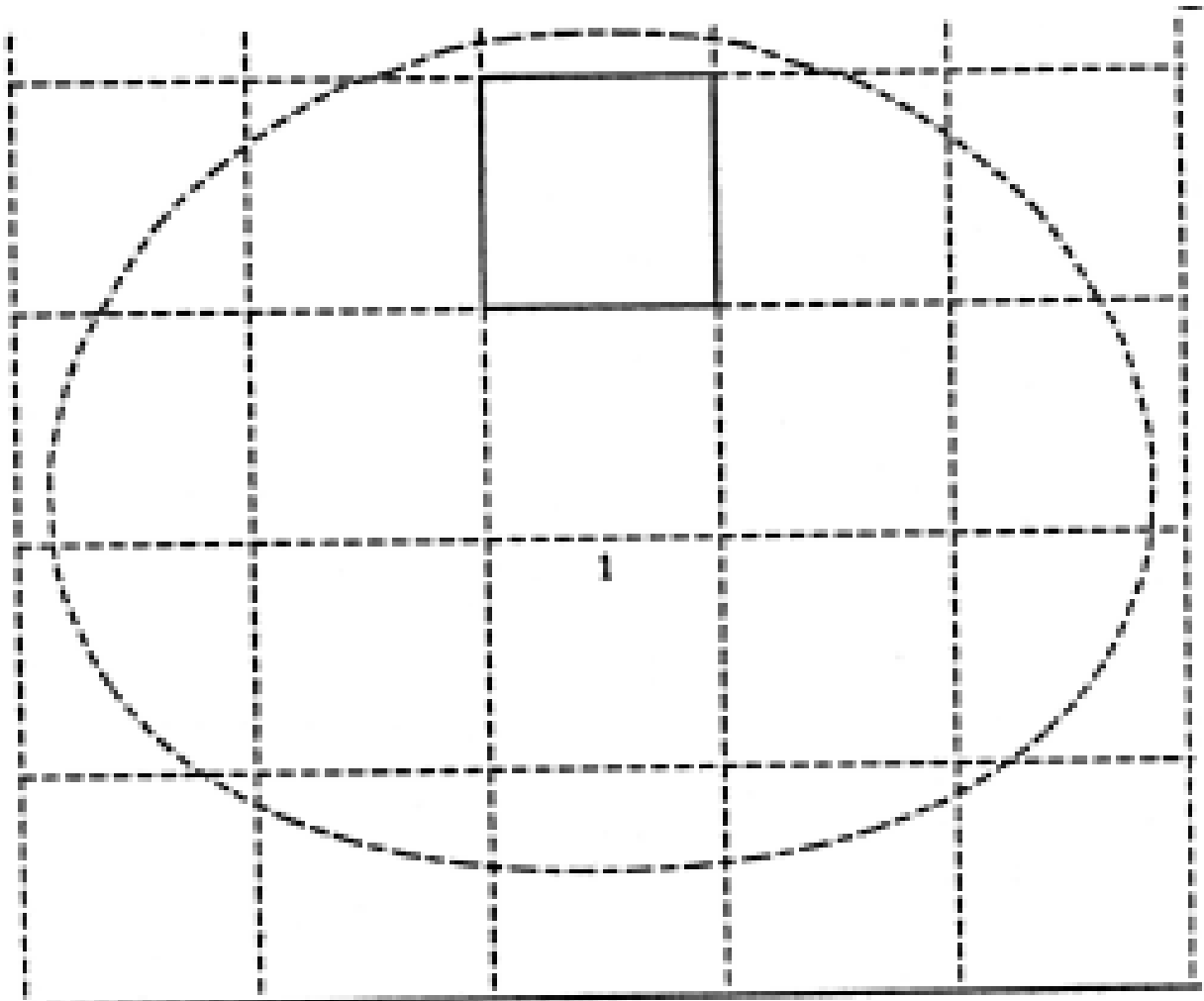

APPENDIX F

GDDM FOOTPRINTS

A-18 H/W = 1.0; S/H = 4.0

APP F 9

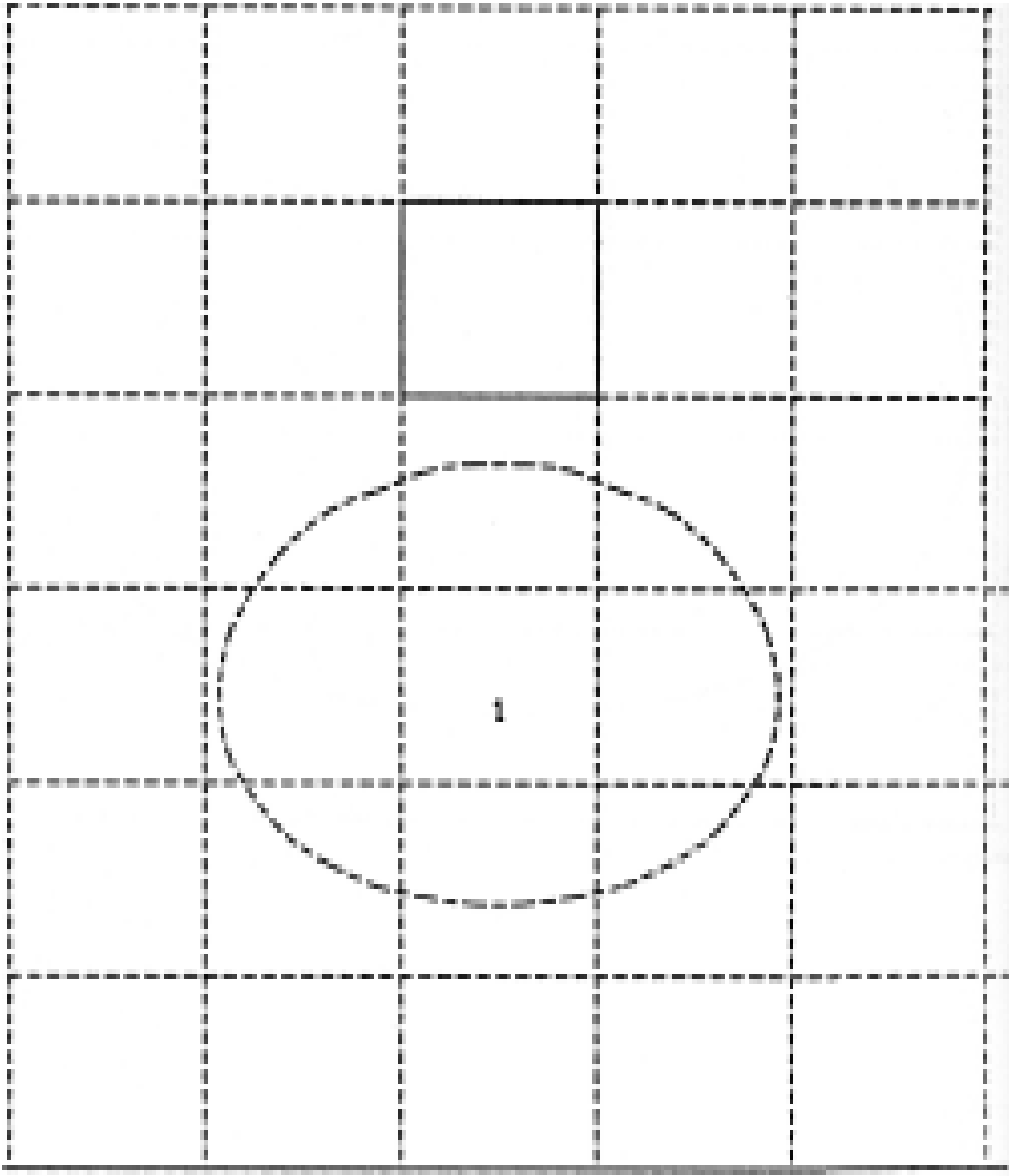

APPENDIX F

GDDM FOOTPRINTS

A-19 $H/W = 2.0$; $S/H = 0.0$

APP F 10

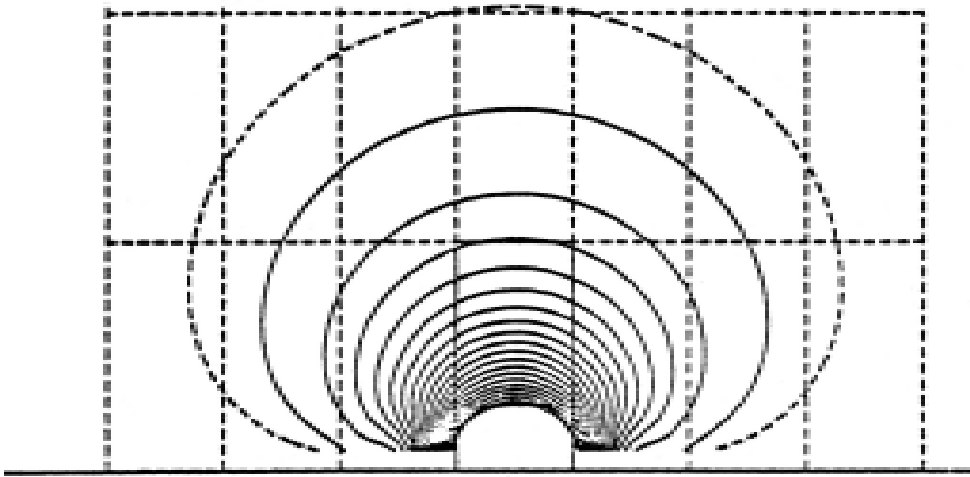

A-20 $H/W = 2.0$; $S/H = 0.25$

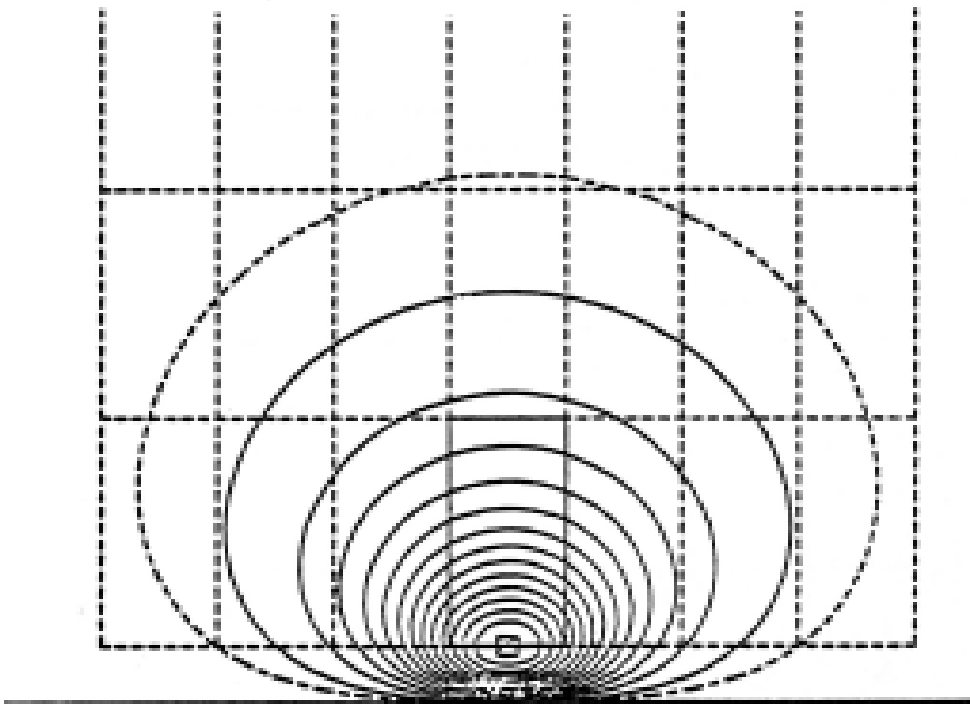

APPENDIX F

GDDM FOOTPRINTS

A-21 $H/W = 2.0$; $S/H = 0.5$

APP F 11

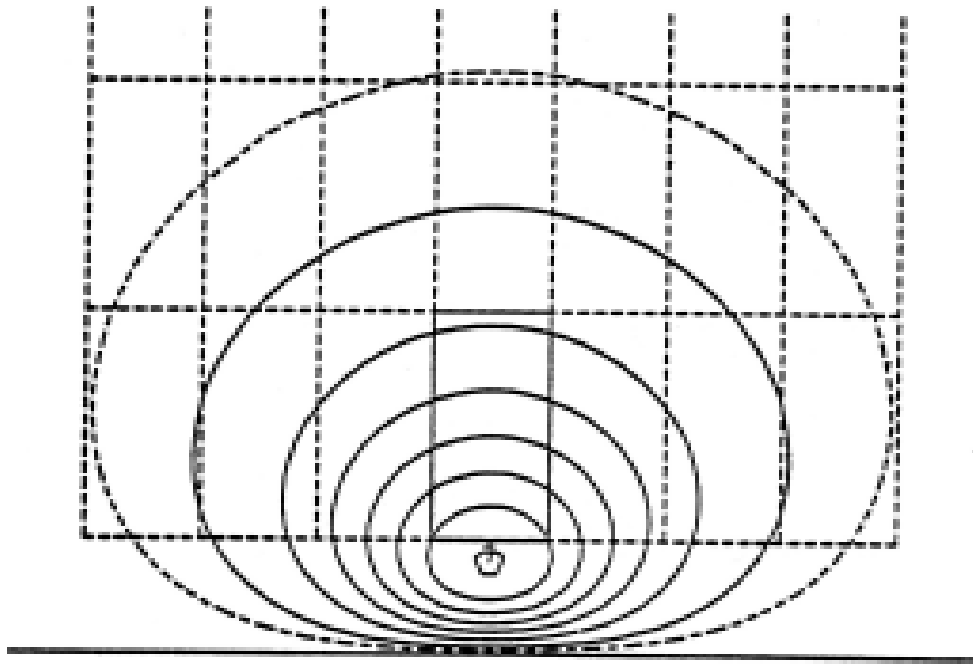

A-22 $H/W = 2.0$; $S/H = 1.0$

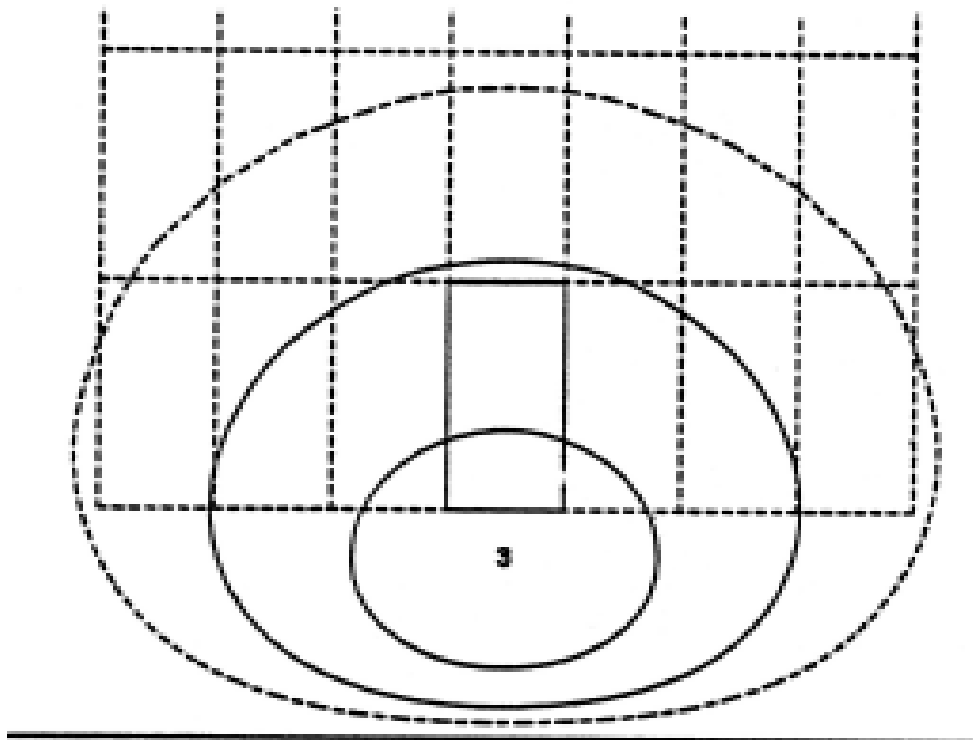

APPENDIX F

GDDM FOOTPRINTS

A-23 H/W = 2.0; S/H = 1.5

APP F 12

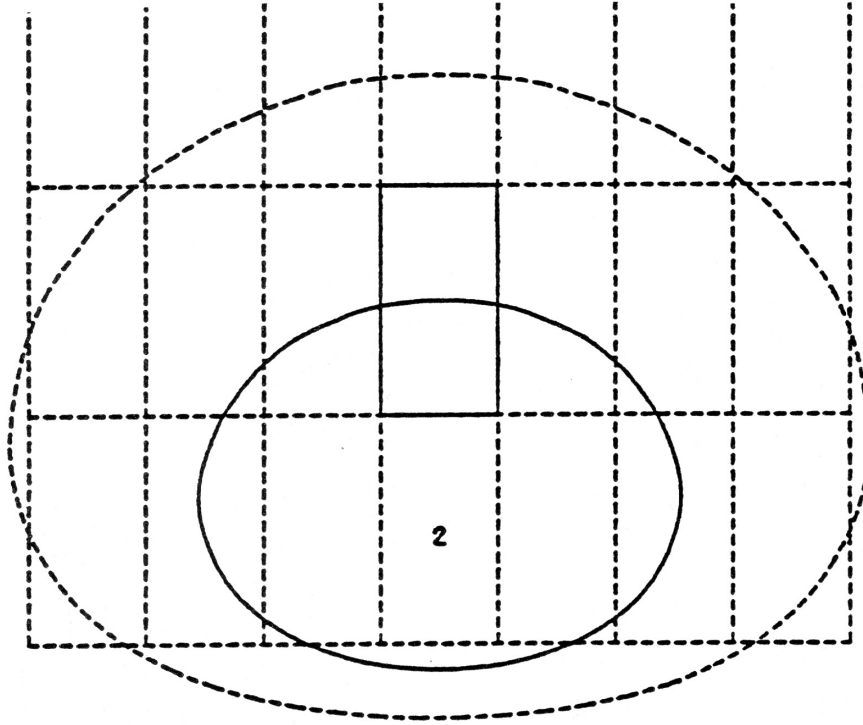

A-24 H/W = 2.0; S/H = 2.0

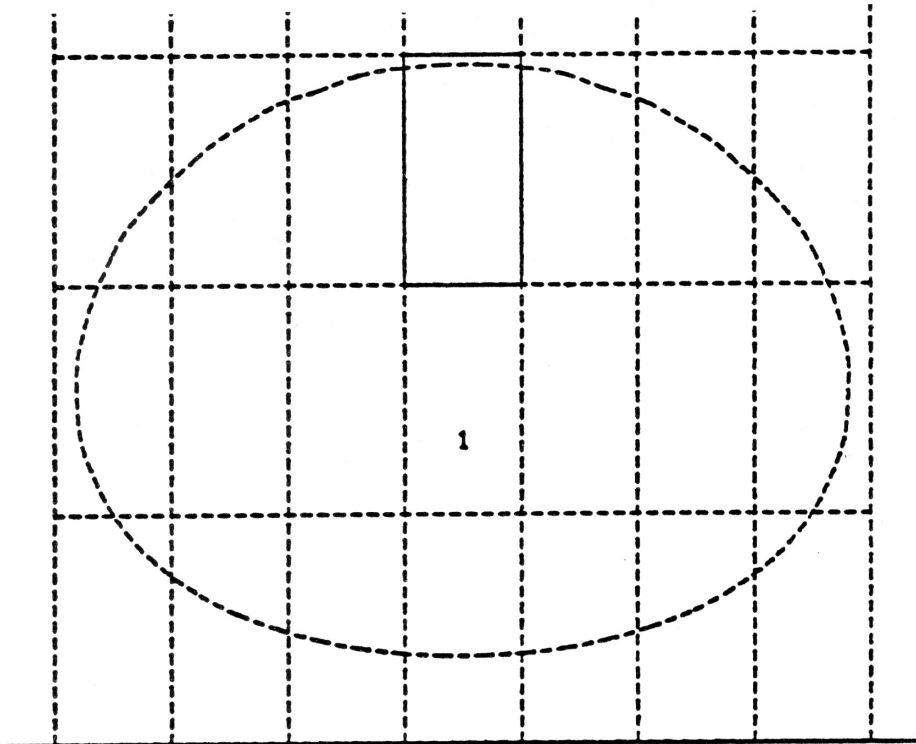

APPENDIX F

GDDM FOOTPRINTS

A-30 L/W = 1.0; S/W = 1.0

APP F 13

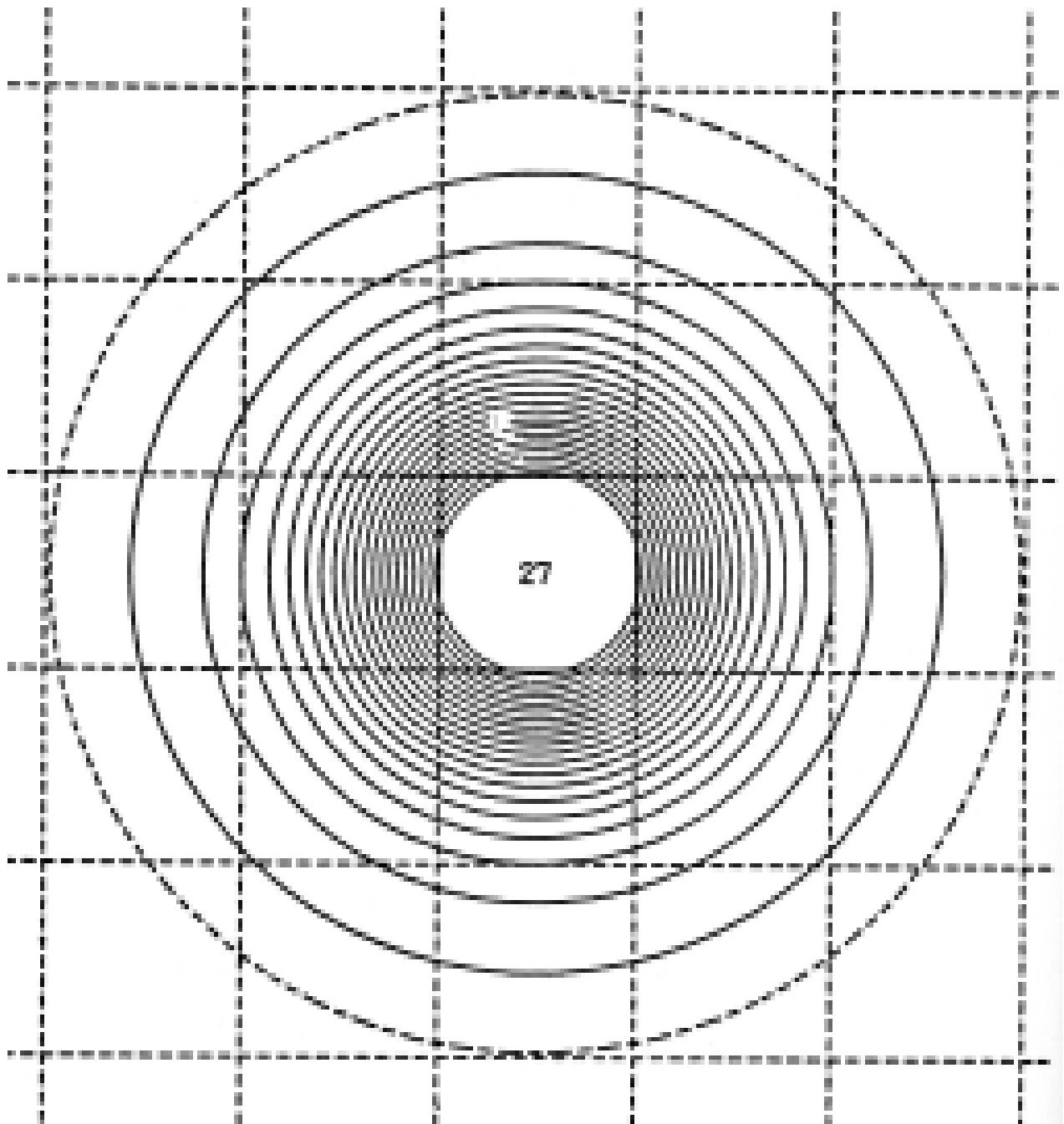

APPENDIX F

GDDM FOOTPRINTS

A-31 L/W = 1.0; S/W = 2.0

APP F
14

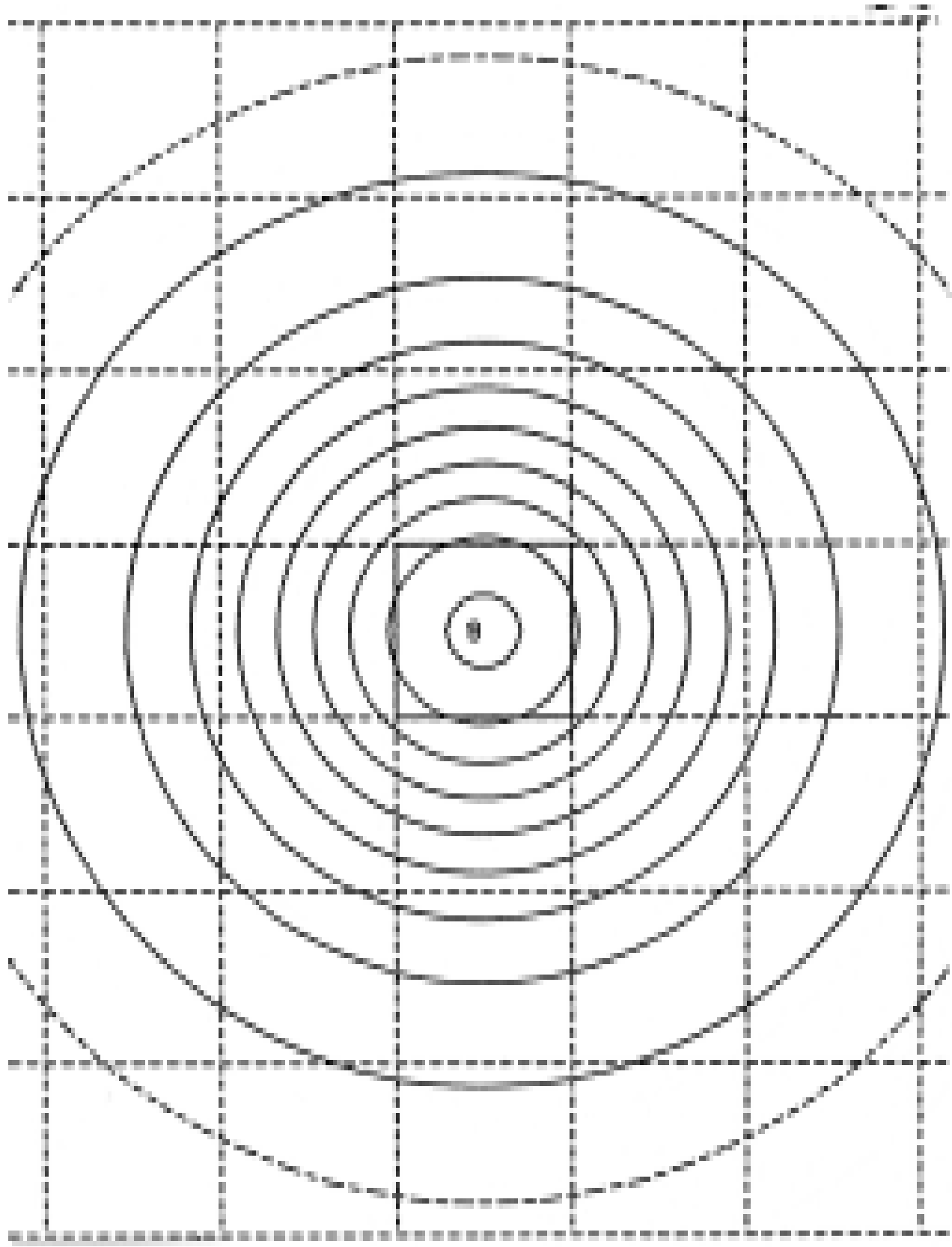

APPENDIX F

GDDM FOOTPRINTS

A-32 L/W = 1.0; S/W = 3.0

APP F
15

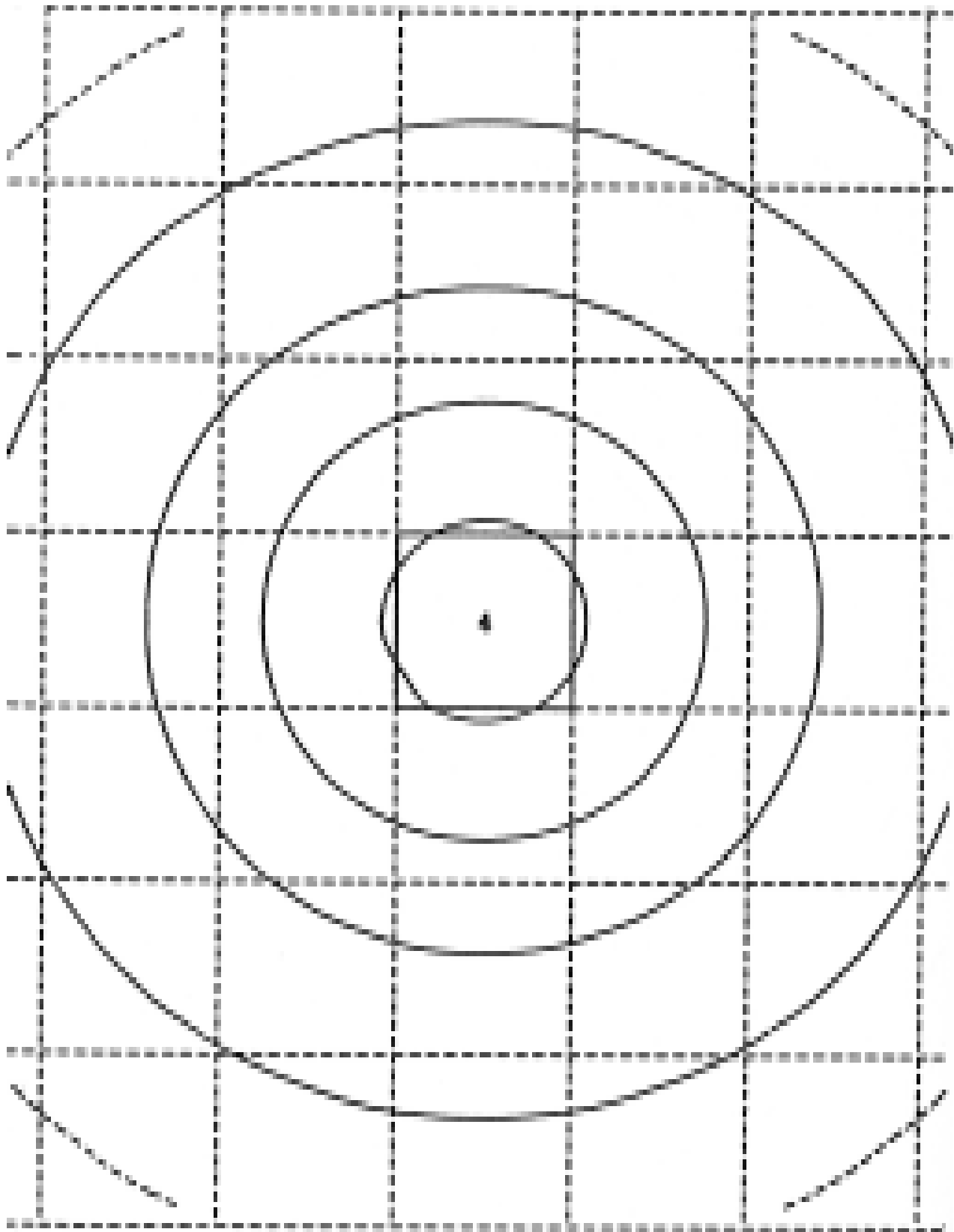

APPENDIX F

GDDM FOOTPRINTS

A-33 L/W = 1.0; S/W = 4.0

APP F 16

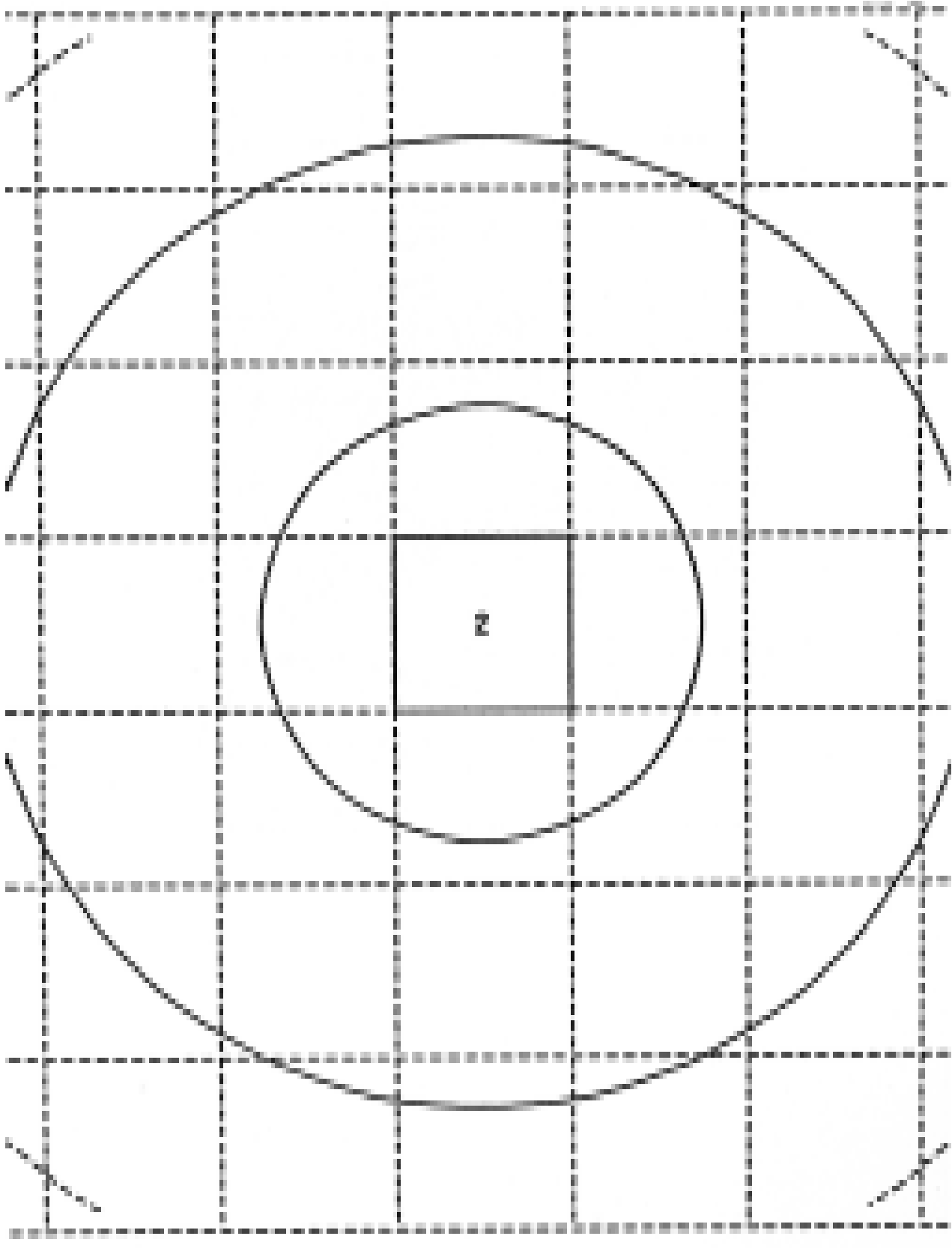

APPENDIX F

GDDM FOOTPRINTS

A-34 L/W = 2.0; S/W = 1.0

APP F

17

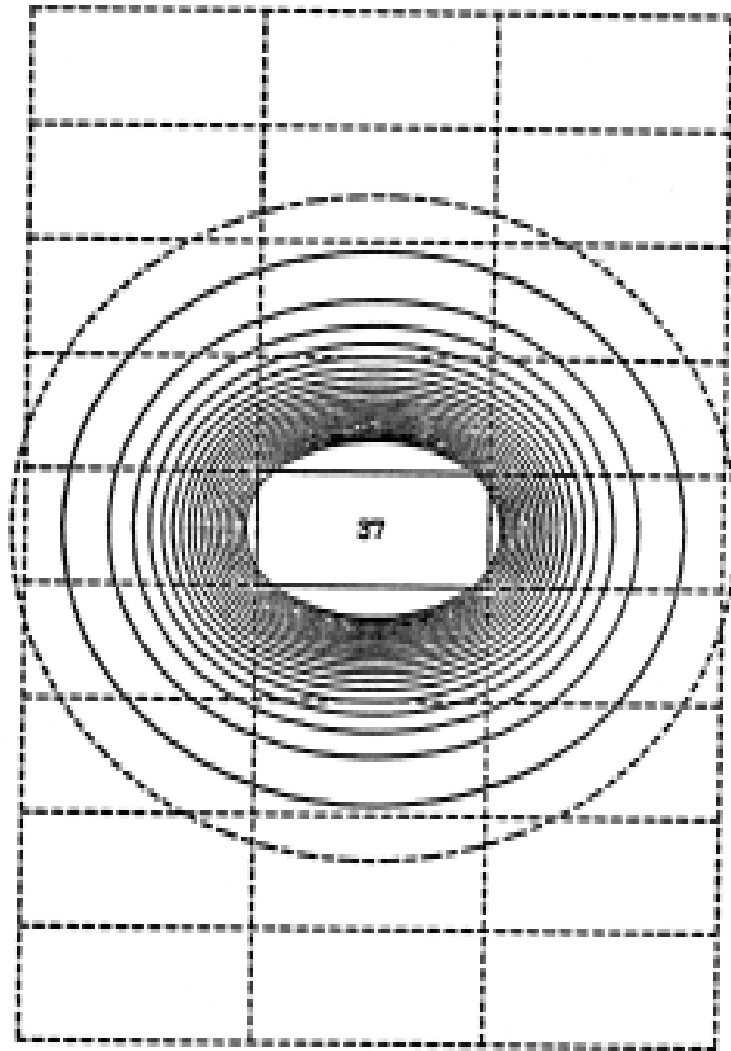

APPENDIX F

GDDM FOOTPRINTS

A-35 L/W = 2.0; S/W = 2.0

APP F
18

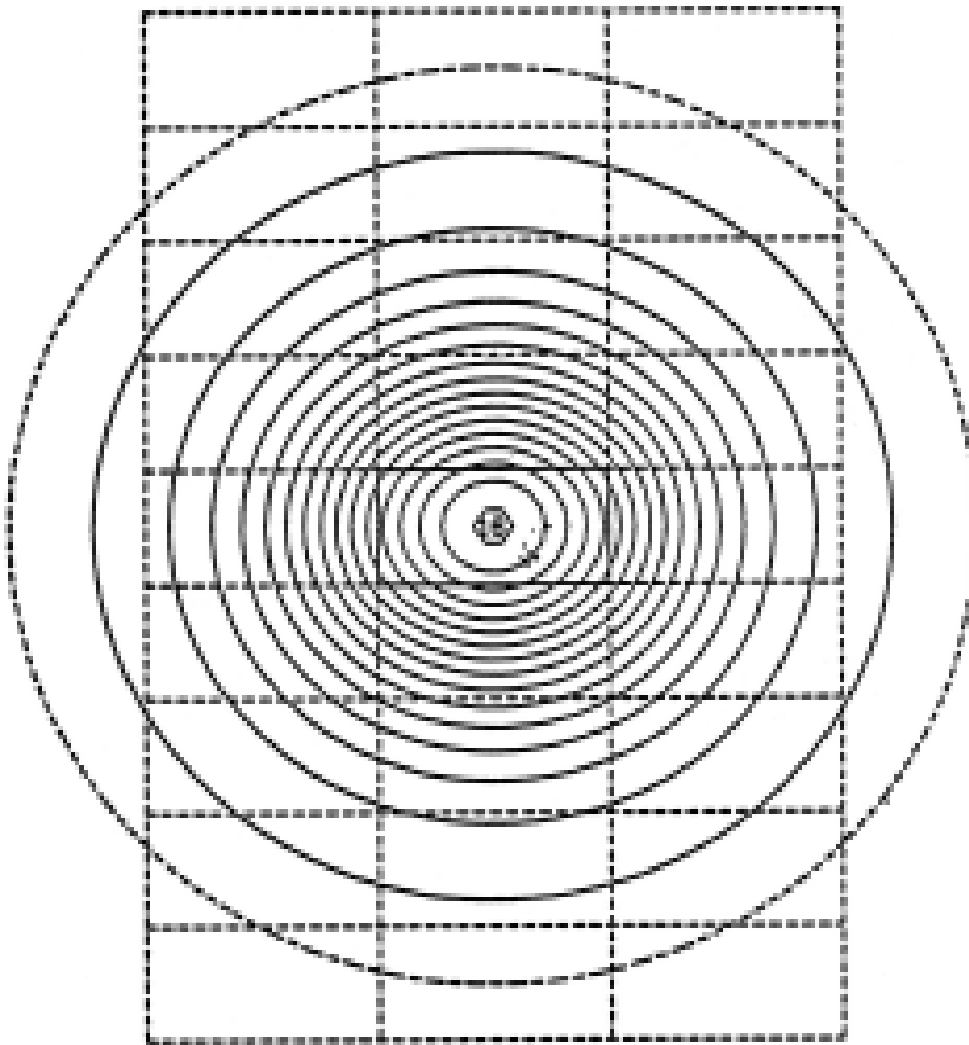

APPENDIX F

GDDM FOOTPRINTS

A-36 L/W = 2.0; S/W = 3.0

APP F 19

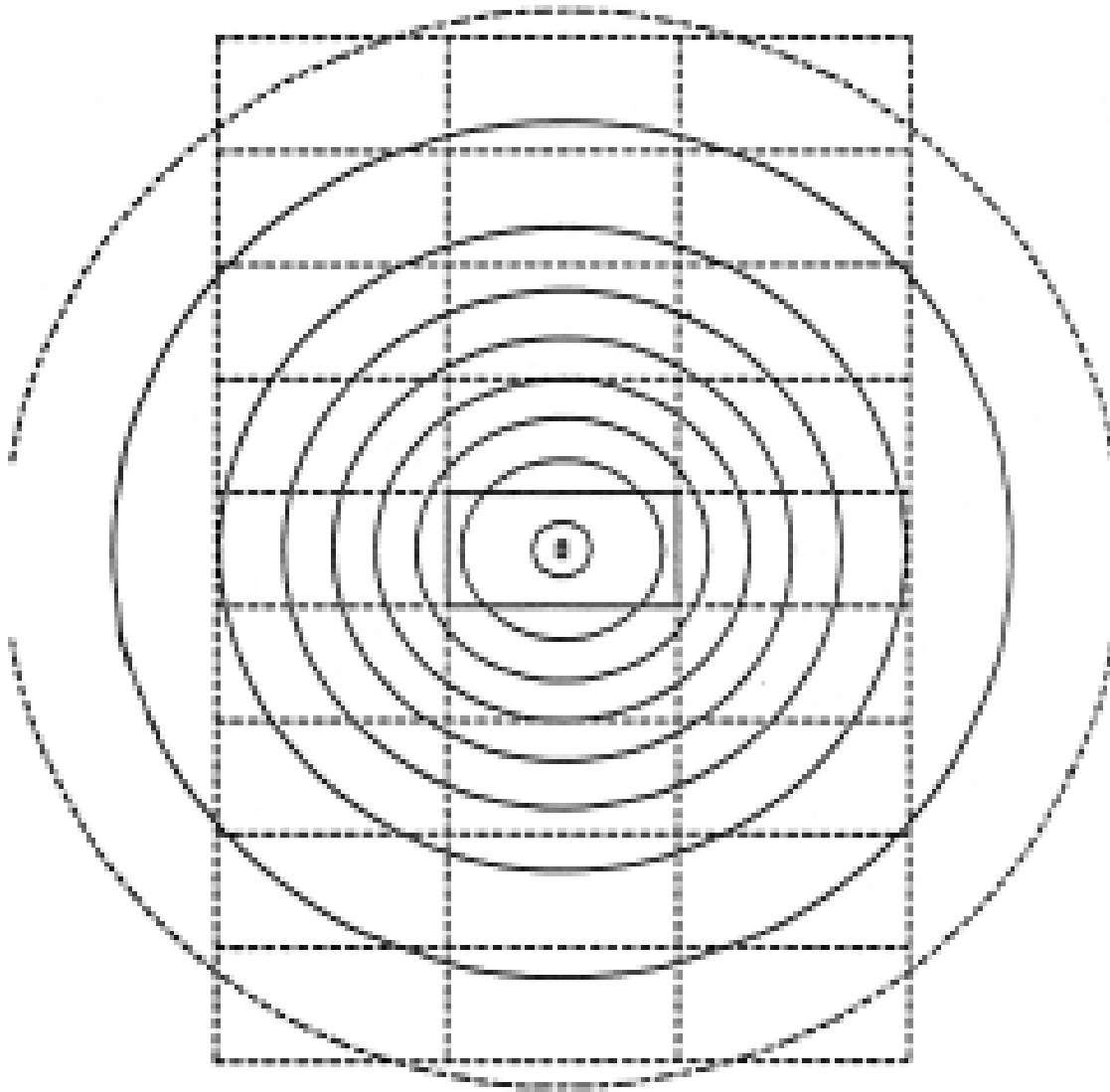

APPENDIX F

GDDM FOOTPRINTS

A-37 L/W = 2.0; S/W = 4.0

APP F
20

