

TEAM BLACKFRIARS

Ciera Shaver Meghan Craig Brandon Taylor Tim Christensen

Hosted by: Cullinan Studio

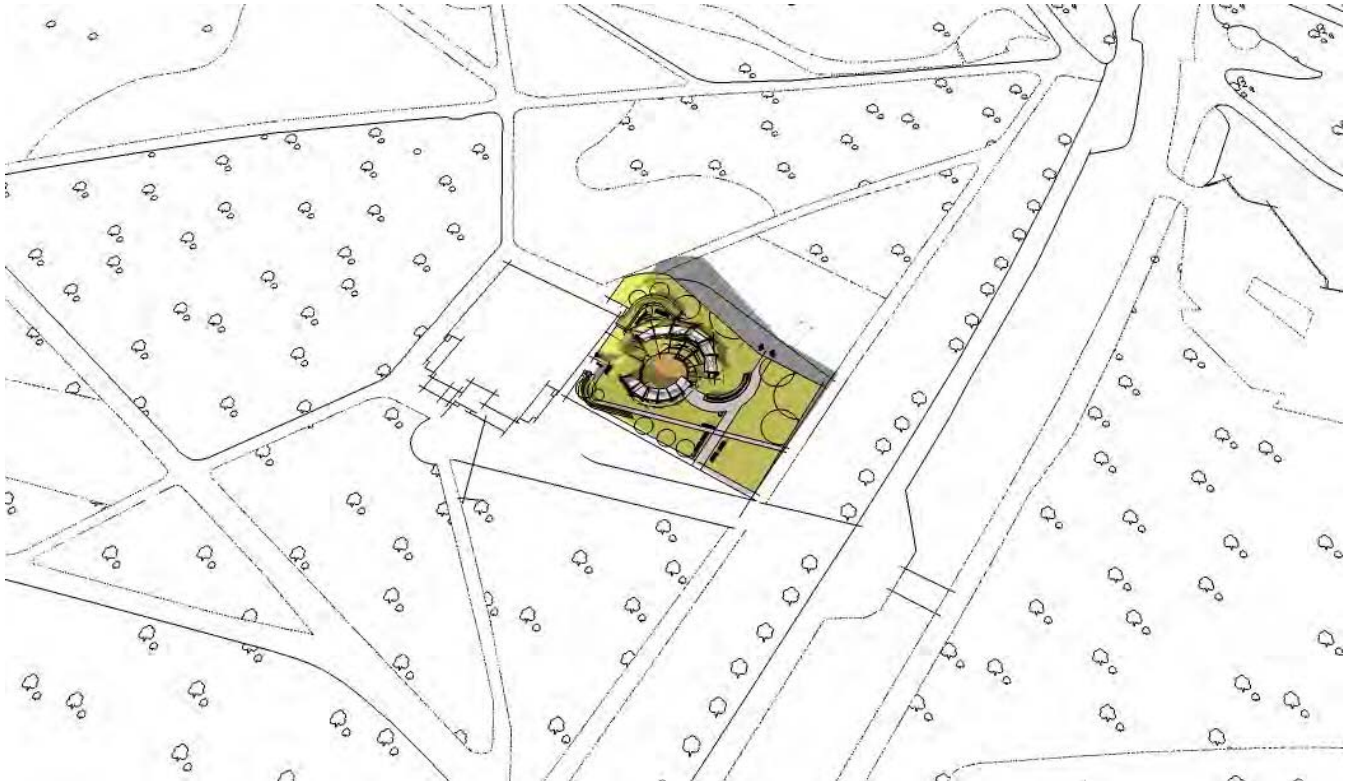

BRIEF: The appointed architectural practice may wish to consider -

- + The historic, social and physical context of the Serpentine, together with the history and layout of the existing building, and the Gallery's Exhibition, Education and Public Programmes
- + An innovative use of materials, both new and traditional
- + The Serpentine Gallery's cultural mission to present international modern and contemporary art, architecture and education and public programmes to a diverse and international audience
- + The visitor's experience of art, architecture, education and public programmes within the 'natural' setting of a large green space in central London
- + A design that does not obscure the Serpentine's east façade, but enhances the relationship between gallery, lawn, terrace and park landscape
- + The windows in the East Gallery overlooking the Serpentine's lawn may remain open, which means that visitors to the exhibition will be able to view the Pavilion from inside the Gallery. The design of the Pavilion therefore should respond to the possibility of being experienced from this vantage point

GOAL:

- + To design an environmentally conscious pavilion that is influenced by **London's culture**, through the form and end use.

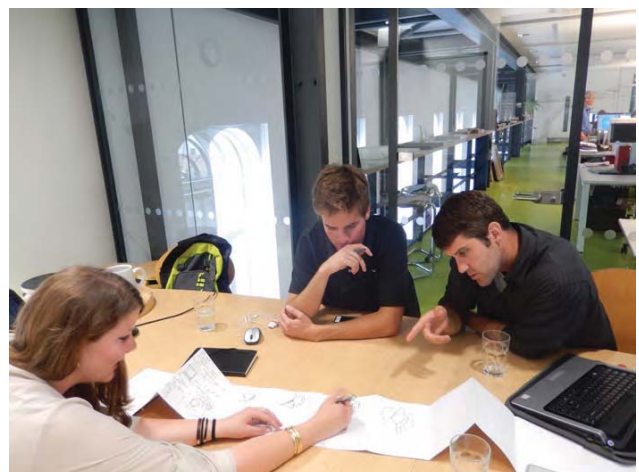

PRECEDENTS:

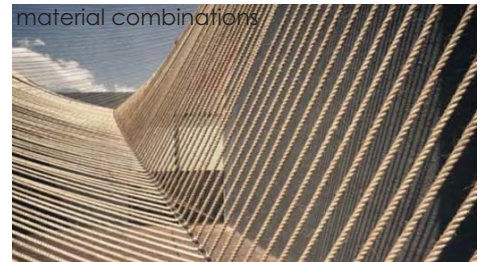

SITE ANALYSIS:

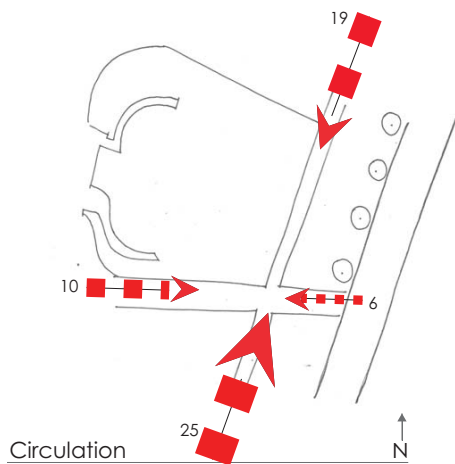
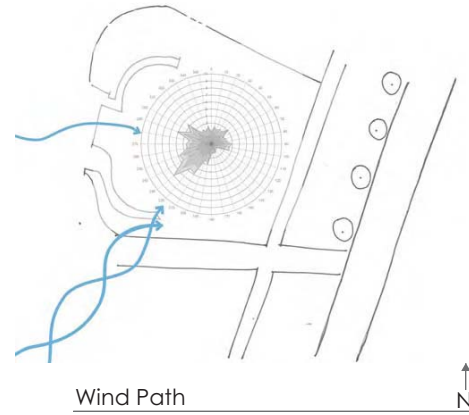
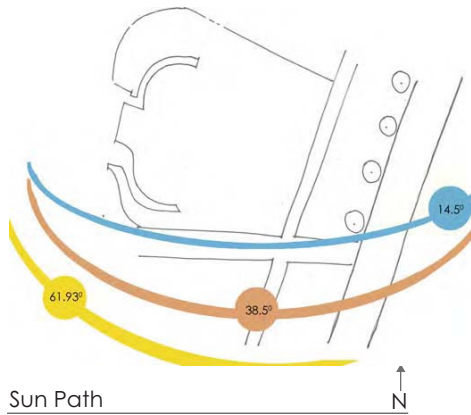

CONCEPT DIAGRAMS:

To design an environmentally conscious pavilion that is influenced by **London's culture**, through the form and end use.

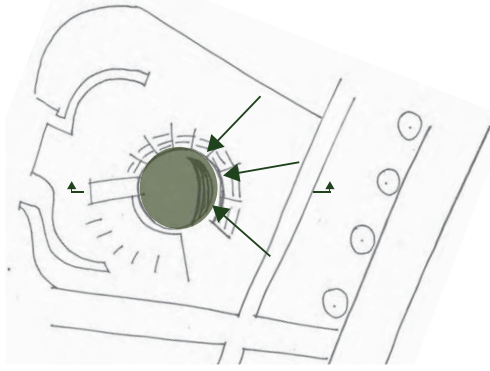

A submerged environment

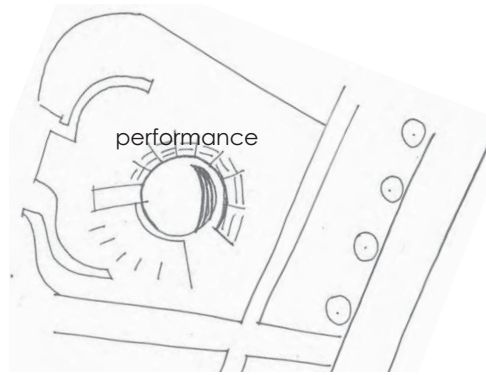

A space for educating

poetry readings
open discussions
dance recitals



Environmentally conscious

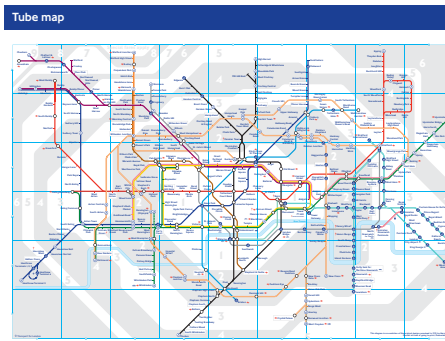

While considering context

PROCESS:

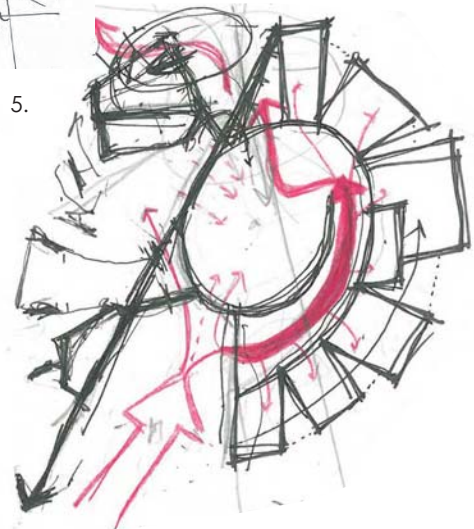
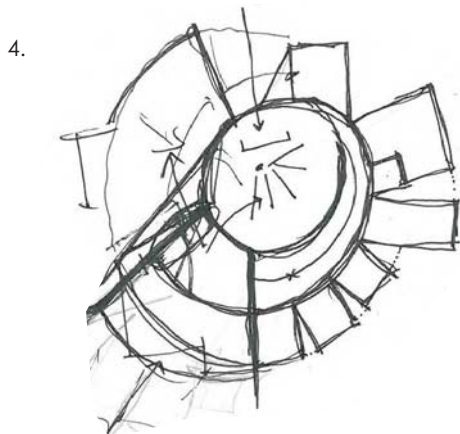
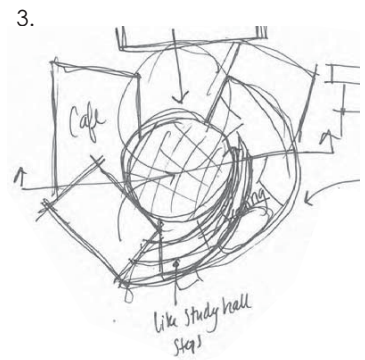
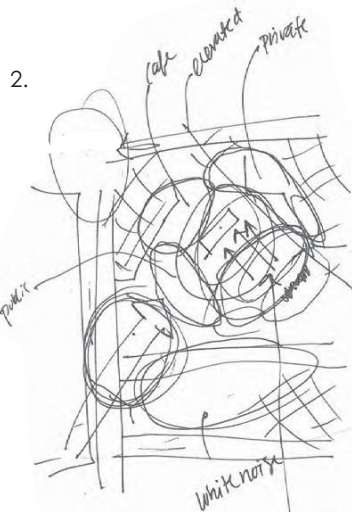
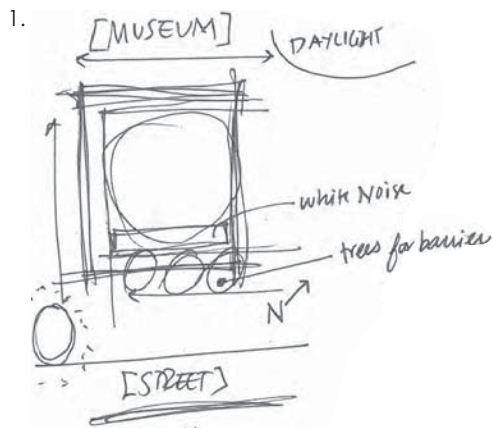

SITE PLAN:



Site Plan

PROGRAM:

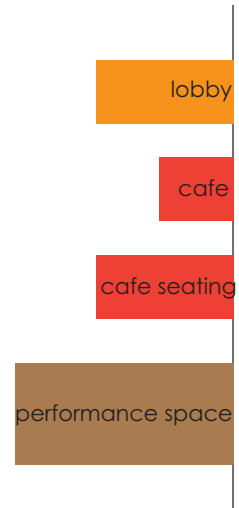

5 sqm (50sqf) - Lobby

19 sqm (204sqf) - Cafe

67 sqm (721sqf) - Performance space

SECTIONS + DETAIL:



Section - S1

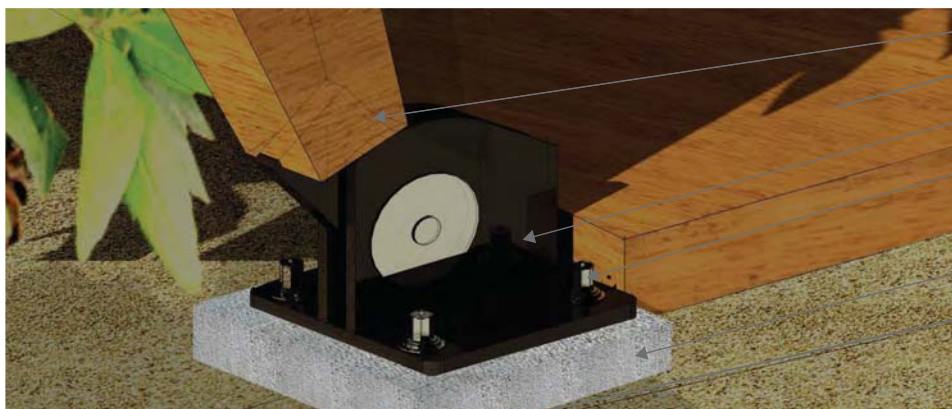

Connection Detail

- Glulam from recycled timber
- Recycled shipping pallets
- Steel connection
- Bolted connection
- Concrete footing
- Screw pile foundation

PERSPECTIVES:



Approach



Cafe



Performance Space

REGENERATION-BASED CHECKLIST:

Regeneration-Based Checklist for Design and Construction

© SBSE @ Tadoussac 1999

Project:		degeneration						sustainability						regeneration						
		-100 always		-75 usually		-50 sometimes		-25 a bit		0 balances		25 a bit		50 sometimes		75 usually		100 always		
the site	pollutes air																		cleans air	
	pollutes water																		cleans water	
	wastes rainwater																		stores rainwater	
	consumes food																		produces food	
	destroys rich soil																		creates rich soil	
	dumps wastes unused																		consumes wastes	
	destroys wildlife habitat																		provides wildlife habitat	
	imports energy																		exports energy	
	requires fuel-powered transportation																		requires human-powered transportation	
	intensifies local weather																		moderates local weather	
	the building	excludes daylight																		uses daylight
		uses mechanical heating																		uses passive heating
uses mechanical cooling																			uses passive cooling	
needs cleaning and repair																			maintains itself	
produces human discomfort																			provides human comfort	
uses fuel-powered circulation																			uses human-powered circulation	
pollutes indoor air																			creates pure indoor air	
is built of virgin materials																			is built of recycled materials	
cannot be recycled																			can be recycled	
serves as an icon for the apocalypse																			serves as an icon for regeneration	
is a bad neighbor																			is a good neighbor	
is ugly																			is beautiful	

negative score	positive score
2200 possible	2200 possible
25	1200
final score: 1175	

SYNOPSIS:

Our design achieves our goal of creating an environmentally conscious pavilion that was influenced by London's active culture. Through the implementation of:

- observing the surrounding context with respect to the Serpentine Gallery
- requiring human powered transportation to the pavilion by foot and bike
- a flexible multi use performance space
- a environmentally conscious cafe menu
- educational recycling graphics showing what you can do and why you should recycle through the activity of doing so
- sustainable strategies further reinforced through visual elements by the engagement of the occupants in the pavilion
 - pavilion orientation
 - daylighting
 - natural ventilation
 - material palette



Southern Aerial



Northern Aerial